



**DOG™**  
T R A C E

ČESKY

ENGLISH

DEUTSCH

POLSKI

---

**DOG** | X<sub>20+</sub>  
G P S

---

GPS VYHLEDÁVACÍ ZAŘÍZENÍ  
GPS TRACKING SYSTEM  
GPS HUNDEORTUNGSGERÄT  
LOKALIZATOR GPS DLA PSÓW

---

## DECLARATION OF CONFORMITY

We:

VNT electronics s.r.o.

Dvorská 605

563 01 Lanškroun

IČO: 64793826

declare under own responsibility that the product:

**Dogtrace**

**DOG GPS X20+**

is in compliance with the essential requirements and other relevant provisions of Directive 2014/53/EC, meets requirements of General Licence of The Czech telecommunication office according to general licence no. VO-R/10/05.2014-3 and corresponds to the following standards:

**ETSI EN 301 489-1 V1.9.2**

**ETSI EN 301 489-3 V1.6.1**

**ETSI EN 300 220-2 V.2.4.1**

**ETSI EN 60950-1 ed.2:2006 /A1:2010 /A11:2009 /A12:2011 /A2:2014/Cor.1:2012  
EN 62479:2010**



The product is safe under conditions of standard use in accordance with the user guide.

This declaration of Conformity is created in exclusive responsibility of producer.

In Lanškroun 1. 1. 2018

Ing. Jan Horák

executive director

Tel.: +420 461 310 764

info@dogtrace.com

**www.dogtrace.com**

Thank you for purchasing the product **DOG GPS** of the trademark **Dogtrace** from **VNT electronics s.r.o.**, Czech Republic.

Before using your product, please read the instructions in this user guide carefully and keep it for future reference.

Hereby, **VNT electronics s.r.o.**, declares that this **Dogtrace DOG GPS X20+** is in compliance with the essential requirements and other relevant provisions of Directive 2014/53/EC.

<b>2</b>	<b>Important notice</b>	<b>22</b>
<b>3</b>	<b>ECMA</b>	<b>22</b>
<b>4</b>	<b>Introduction</b>	<b>23</b>
4.1	Features of DOG GPS X20	23
4.2	Package contents	23
4.3	Optional accessories	23
<b>5</b>	<b>Product description</b>	<b>24</b>
5.1	Transmitter (collar)	24
5.2	Receiver (handheld device)	24
5.3	Power supply adapter and cable with a rechargeable clip	27
<b>6</b>	<b>Transmitter preparation (collar)</b>	<b>27</b>
6.1	Transmitter charging	27
6.2	Checking the accumulator status in transmitter (collar)	27
6.3	Switching the transmitter (collar) ON/OFF	28
6.4	Position interval (transmission) update	28
6.5	Fitting the collar	28
<b>7</b>	<b>Receiver preparation (handheld device)</b>	<b>29</b>
7.1	Receiver charging	29
7.2	Receiver accumulator status check	29
7.3	Receiver setting	29
7.4	Pairing – coding of transmitter (collar) with receiver (handheld device)	29
7.5	Digital compass calibration	30
<b>8</b>	<b>Functions of DOG GPS X20</b>	<b>31</b>
8.1	Locator	31
8.2	Compass function – north determination	32
8.3	Function FENCE – akustic border	32
8.4	WAYPOINT – storing the receiver position	33
8.5	BEEPER function	33
8.6	CAR mode	35
<b>9</b>	<b>Maximum range and GPS accuracy</b>	<b>36</b>
<b>10</b>	<b>Troubleshooting</b>	<b>36</b>
<b>11</b>	<b>Device maintenance</b>	<b>37</b>
<b>12</b>	<b>Technical specifications</b>	<b>37</b>
<b>13</b>	<b>Warranty terms and conditions</b>	<b>38</b>
<b>14</b>	<b>Certificate of warranty</b>	<b>80</b>

- Carefully study the instructions for use prior using the product.
- The collar should never be worn for more than 12 hours a day. Long-term effect of the collar on the dog's skin can cause skin irritation. If a rash or sore skin is found, do not use the DOG GPS until it has healed.
- Do not place the receiver or transmitter close to objects which are sensitive to magnetic field, this could cause a permanent damage to the object.
- Do not place the receiver close to objects which generate magnetic field – it could affect inner electronic compass.
- The receiver and transmitter contain rechargeable accumulator Li-Pol. Even when you are not using DOG GPS, it is necessary to recharge the accumulators every 6 months.
- Do not recharge accumulator in an environment with a higher temperature than 40 °C - risk of explosion.
- Protect the Li-Pol accumulator from damage by sharp objects, high mechanical pressure and high temperatures. It could cause fire or explosion of accumulator.
- Do not use other than original accumulators – it could cause damage of the product or explosion of accumulator.
- To charge the accumulator in the receiver and transmitter use only the original power adapter with charging clip.
- Dispose of used accumulators to a designated location.
- The person with a personal instrument to support heart activity (pacemaker, defibrillator) must respect the relevant precautionary measures. The DOG GPS emits a certain stationary magnetic field.



**VNT electronics s.r.o.**, professional producer of the dog training equipment, which is manufactured and sold under the brand name Dogtrace, is a proud and active member of the **Electronic Collar Manufacturers Association**.

ECMA was founded in Brussels in 2004 as a result of increasing awareness from different manufacturers concerning the necessity of regulating their industry. The main target of the association is to develop and produce reliable training systems of high quality, which are safe for the animals and improve the communication between pets and their owners. All members of the ECMA provide you with both technical and training guides that contain instructions and advice for safe use of electronic training equipment and enable all dog owners to use the training systems in an effective, responsible and humane way. All ECMA member's products meet the latest technical requirements which ensure minimum production standards and safety features and enable training while protecting animal welfare.

The ECMA is convinced that the electronic training collars are effective and humane training tools when used responsibly and combined with an appropriate reward.

For more information please visit [www.ecma.eu.com](http://www.ecma.eu.com).

**DOG GPS X20** is a device used for detection (localization) of your dog up to a distance of 20 km. It consists of a transmitter, which is placed on the dog collar and a receiver (handheld device) on which the handler monitors the position and the distance of the dogs. The transmitter obtains its location from the GPS satellites and with help of a radio frequency signal (RF) transmits the information about the position to the handlers receiver. On the receiver display you can also check strength of RF signal, GPS signal and accumulator status of the transmitter and the receiver.

DOG GPS X20 also features of an additional functions: compass, FENCE – acoustic border, which provides information about the dog crossing the boundaries in a specified distance from the receiver. Also it has a function BEEPER which shows, if the dog is in motion or still. The receiver allows storing its current position and then navigating to this position (the waypoint function).

#### 4.1 Features of DOG GPS X20

- The range between transmitter and receiver is up to 20 km in open space (depending on terrain, vegetation, other factors)
- Monitoring up to 9 dogs on one receiver
- High sensitivity GPS in receiver and transmitter
- Well readable display - in direct sunlight and in the dark
- Waterproof receiver and transmitter
- Long accumulator stamina
- Function compass
- Function FENCE – acoustic border, which set out the space for a dog
- Function BEEPER – motion/motionlessness detection
- WAYPOINT function – ability to store 4 GPS coordinates of the receiver – and navigation to these points
- CAR MODE function – mode for using the receiver (manual device) in a car

#### 4.2 Package contents

- Receiver including rechargeable accumulator Li-Pol 1900 mAh
- Belt clip for the receiver and 2 pieces of screws
- Transmitter including rechargeable accumulator Li-Pol 1900 mAh, strap
- Dual power adapter, 2 pcs of USB cable with recharge clip for GPS
- Lanyard for receiver
- User guide and certificate of warranty
- Carrying case

#### 4.3 Optional accessories

- Spare transmitter and receiver
- Various colours straps
- Transmitter protective cover
- Li-Pol accumulator Li-Pol 1900 mAh
- Power adapter with USB cable and clip GPS
- Spare silicone sleeves for the transmitter – black, orange

### 5.1 Transmitter (collar)

1. Transmitter
2. LED indicators
3. Charging contacts
4. Target, (half round red indicator) indicating where the magnetic switch is located
5. RF antenna
6. GPS antenna
7. Strap (collar)

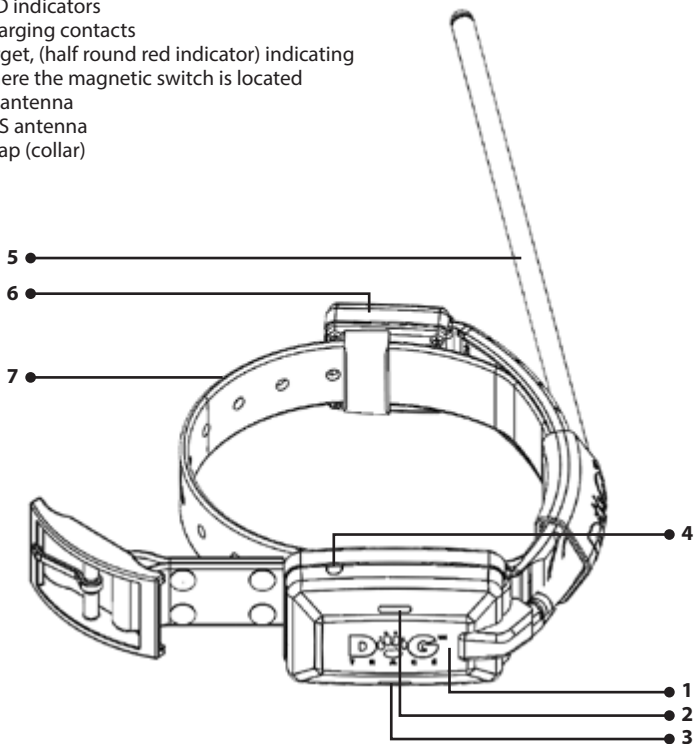

### 5.2 Receiver (handheld device)

- |  |   |
|--|---|
| <ol style="list-style-type: none"> <li>1. - 4. Buttons (see the table on pg. 25)</li> <li>5. RF antenna</li> <li>6. GPS antenna</li> <li>7. Display</li> <li>8. Target (half round indicator) indicating where the magnetic switch is located</li> </ol> | <ol style="list-style-type: none"> <li>9. Belt clip</li> <li>10. Hole for lanyard</li> <li>11. Charging contacts</li> </ol> |
|--|---|

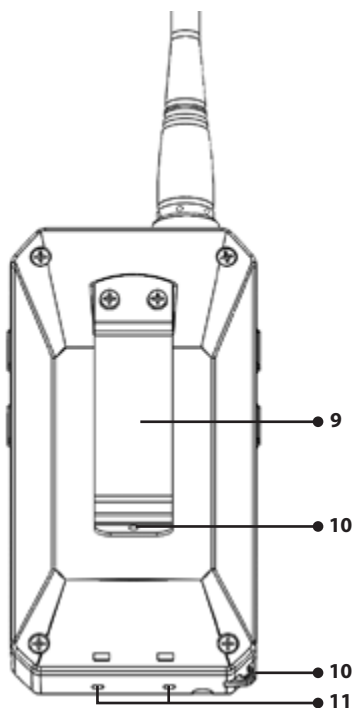
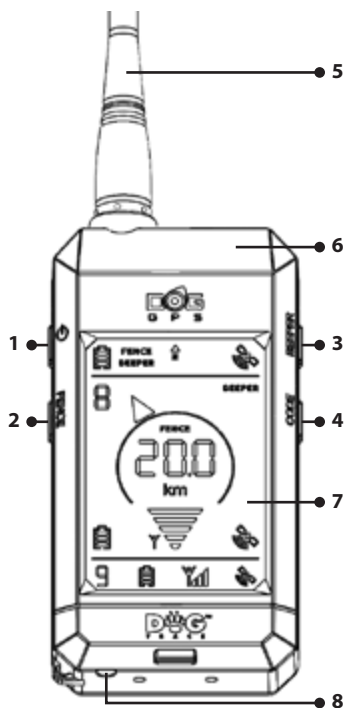

Button	Short press		Long press	
	1	☀	backlight switch ON/OFF	⏻
2	↩	back to the main screen	<b>FENCE</b>	function FENCE activation
3	▲	up	<b>BEEPER</b>	function BEEPER activation – detection of dog motion
4	▼	down	<b>CODE</b>	pairing – programming transmitter with receiver
2+4			↩+▼	CAL – Calibration of the electronic compass
1+3			⏻+ <b>BEEPER</b>	CAR mode OFF/ON

## Display

- Indicator of the GPS position accuracy of the receiver (handheld device)
- Indicator of the GPS position accuracy of the transmitter (collar)
- Indicator of the GPS position accuracy of the next transmitter
- Indicator of the RF signal received from the transmitter
- Indicator of the RF signal received from the next transmitter
- Direction indicator to a paired transmitter
- Number of the chosen paired transmitter
- Number of the next paired transmitter
- The accumulator charge status of the receiver
- The accumulator charge status of the transmitter
- The accumulator charge status of the next transmitter
- The distance of the transmitter to the receiver
- Compass - direction to the magnetic north (N)
- Active function BEEPER on one of the dogs
- Active function FENCE on one of the dogs
- Active function BEEPER
- Active function FENCE

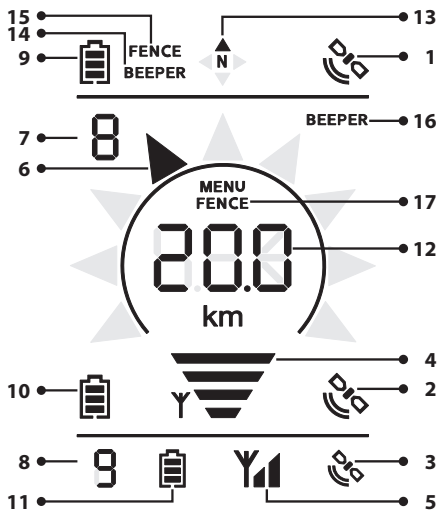

Receiver information panel

Navigation main panel - for currently chosen transmitter (collar)

Transmitter (collar) information panel - for next paired transmitter in a row



### 5.3 Power supply adapter and cable with a rechargeable clip

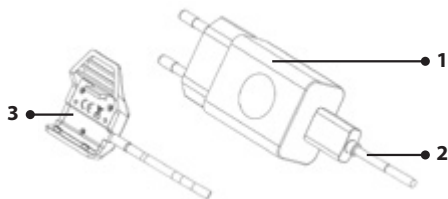

1. Power supply adapter
2. USB cable
3. Charging clip

## 6 TRANSMITTER PREPARATION (COLLAR)

### 6.1 Transmitter charging

Transmitter GPS contains Li-Pol accumulator. The accumulator must be recharged before first use.

1. Before charging clean the transmitter charging contacts from any dirt. Connect the charging clip to the transmitter (see the picture).
2. Connect supply cable to power adapter and plug it into the mains.
3. The orange LED indicator on the transmitter will lit up.
4. Charging time is approximately 3 hours.
5. When the charging is completed, the orange LED indicator goes OFF.

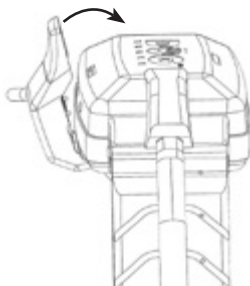

**WARNING:** Optimal temperature for charging is from 0 °C up to 40 °C. Use only the original power adapter supplied in the packing with the device. Other chargers could damage the accumulator.

### 6.2 Checking the accumulator status in transmitter (collar)

The status of the accumulator is indicated by LED indicators on the top side of the transmitter (see chapter: *5.1 Product description – transmitter*) or symbol of battery on the LCD of the receiver (handheld device).

status charge	receiver	transmitter
100%		green LED indicator
70%		—
40%		green and red LED indicator together
10%		red LED indicator

### 6.3 Switching the transmitter (collar) ON/OFF

To turn the transmitter ON/OFF is used a magnetic switch, which is activated by enclosing a magnet. Magnet is placed in receiver, marked with the red target (half round target on the bottom part of the receiver).

#### Switching ON:

1. Move the red target on the bottom of the receiver to the red target on the transmitter for about 1 second - the red indicator lights up, followed by the green indicator.
2. When the green indicator lights up, move the receiver from the transmitter. Then the green indicator starts flashing.

#### Switching OFF:

When switching OFF, follow the same way as when switching ON.

1. Move the red target on the bottom of the receiver to the red target on the transmitter for about 1 second - the green indicator lights up, followed by the red indicator.
2. When the red indicator lights up, move the receiver away from the transmitter. The transmitter indicators stop flashing.

### 6.4 Position interval (transmission) update

DOG GPS X20 allows you to select the interval - the update rate for the position (transmission) of your dog. The more frequently collar sends its position, the more up to date information about the position of the dog you have.

1. Turn OFF the transmitter (collar).
2. Move the red target on the bottom side of the receiver close to the red target on the transmitter for 3 seconds - the transmitter will emit an audible beep tone. Choose required interval update according to the number of beeps - see table.

Number of beeps	1	2	3
Update interval [s]	3	6	9

3. To confirm the choice move the receiver from the transmitter away when you hear the required number of beeps.

**Note:** More frequent updates of the dogs position consume the accumulator faster.

### 6.5 Fitting the collar

Fit the collar with a GPS transmitter on the dog as on the picture. GPS and RF antenna must be directed towards the sky. The collar must be tightened so the dog can breathe and eat normally and the collar does not rotate on the dogs neck. We recommend you to fit the collar on the standing dog. Do not leave the dog to wear the collar with the transmitter for more than 12 hours a day. Long exposure of the collar on the dog's skin may cause skin irritation. If it happens, do not use DOG GPS until all traces of irritation are gone.

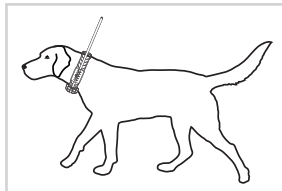

## 7 RECEIVER PREPARATION (HANDHELD DEVICE)

### 7.1 Receiver charging

Receiver contains Li-Pol accumulator. Before first use, the accumulator must be recharged.

1. Before charging clean the receiver charging contacts from any dirt. Connect the charging clip to the receiver (see the picture).
2. Connect supply cable to the power adapter and plug it into the mains.
3. Lines in battery symbol start to show gradually on LCD.
4. Charging time is approximately 3 hours.
5. Accumulator is charged, when the battery symbol is full – see below.

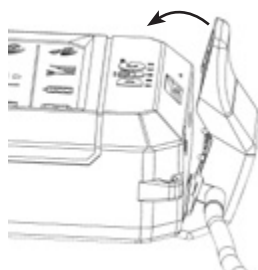

**WARNING:** Optimal temperature for charging is from 0°C up to 40 °C. Use only the original power adapter supplied in the packing with the device. Other chargers could damage the accumulator.

### 7.2 Receiver accumulator status check

The accumulator status of the receiver is indicated on the battery symbol in the Information panel of the receiver - upper display line.

status charge	receiver
100%	
70%	
40%	
10%	

### 7.3 Receiver setting

- Switching receiver ON/OFF – hold the button for 2 seconds.
- To choose the dog, press / .
- To switch ON/OFF the LCD backlight, press shortly backlight will shine for 15 minutes, after that it will switch itself off automatically.

### 7.4 Pairing – coding of transmitter (collar) with receiver (handheld device)

1. Switch ON the receiver and transmitter, which you need to pair together – **switch OFF other transmitters.**
2. Hold the button **CODE** on the receiver for 2 seconds.
3. By arrows / choose the position, to which you want to pair the transmitter (collar). Free position (where there is no paired transmitter) indicates lettering on the LCD.
4. Hold the button **CODE** again for 2 seconds.
5. Bring the transmitter closer to the receiver with their RF antennas parallel to each other.
6. When paired the LCD shows lettering - to (according to the chosen position, to which you've paired the transmitter).

7. If you need to pair another transmitter, follow the procedure from the step 3.

8. To finish the regime of pairing – coding press the button ↵.

**Note:** To delete one of the paired transmitters (collars) from the receiver memory, perform pairing without switched on transmitter. After about 10 seconds, there will be displayed lettering **NO CODE** at chosen position.

## 7.5 Digital compass calibration

To display accurate direction to the transmitter collar, it is important to perform the calibration properly. If the device does not show correct direction even with maximum precision GPS (2 lines on both signal indicators GPS on the display), it has not been probably calibrated for long time or has been calibrated incorrectly.

**WARNING:** Always perform calibration outdoors, away from objects that emit magnetic fields - buildings, cars, overhead and underground power lines.

### Starting calibration

If you know the direction towards to the magnetic north, you can go directly to second step.

1. Press simultaneously two bottom buttons ↵ and ▼ for 2 seconds - to start the calibration. Then step by step rotate the device around each of the three axes (picture no. 1, 2 and 3). To finish calibration press the back button. For more accurate calibration, continue to step 2.
2. Using the compass on the display, look up the north and turn the receiver so that the antenna faces the north (picture no. 4). Press simultaneously two bottom buttons ↵ and ▼ for 2 seconds - to start the calibration.

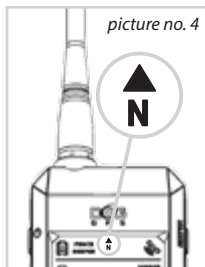
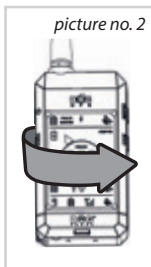

3. Still facing the north perform a minimum of 10 rotations as on the picture no. 5 and no. 6. For quality calibration the each individual rotation should be carried out with little deviation from the north direction (picture no. 7). The slower and more turns you make, the better will be the calibration. To finish, press the back button ↵.

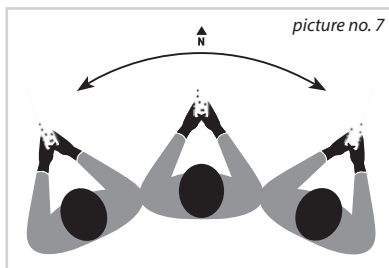
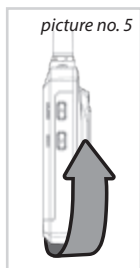

**WARNING:** Accuracy of the direction arrow (pointing to the north) depends on the correct calibration of the electronic compass. Calibrate properly again, when the indication of the direction to the dog is inaccurate.

If we place the transmitter in the vicinity of a magnetic field of another object or device, the digital compass may lose calibration – in that case we need to recalibrate the compass.

## 8

## FUNCTIONS OF DOG GPS X20

### 8.1 Locator

Transmitter (collar) and the receiver (handheld device) have a built-in GPS receiver, which helps them to detect their position. Transmitter emits the information about its position to the receiver with help of a radio signal (RF), display then shows the direction and distance from the dog handler.



**Display is divided in 3 parts:**

- **Receiver information panel** - top line displays information about the receiver - accumulator status, the accuracy of GPS position, the direction of the magnetic north (compass), status of the functions BEEPER and FENCE on one of the paired dogs.
- **The main navigation panel** - the middle part of the display provides information about the currently selected transmitter. Arrow indicator shows the direction to the position of the tracked dog. The middle of the display shows the distance of the dog from the handler. Press ▲ / ▼ to change the displayed dog.
- **Transmitter information panel** - the bottom line displays the data for the next paired transmitters in the row – accumulator status, RF signal strength, the accuracy of GPS position.

**Note:** When the direction and distance indicator of the dog flashes, the receiver has not received information about the GPS position of the dog for longer period, or receiver/transmitter has no GPS signal. In this case, the display indicates the direction and distance to the last known position.

**CAUTION:** When the direction indicator does not show the right direction to your dog, re-calibrate the electronic compass.

### Indicated statuses on the receiver display:



   – receiver has not received information about the position of the dog from the transmitter in a longer period of time.

 – indicator of the RF signal strength flashes – the information about the location of the chosen collar was received.

 – when only the symbol of the RF antenna is flashing – it is not receiving the RF signal from the transmitter.

  – receiver or transmitter have no GPS position.

  – there is no paired transmitter on this position.

   – receiver and transmitter are nearer to each other than the accuracy of the GPS position allows to show.



## 8.2 Compass function - north determination

Symbol **N** indicates the direction of the magnetic north. When two arrows are lit at the same time, the direction of the north is between them.

## 8.3 Function FENCE – akustic border

FENCE function warns you when your dog moves beyond the space that you've had specified. The border is adjustable within a radius of 30 m up to max. 2 km away from the receiver. FENCE function can be activated for more dogs, the settings are stored for each dog separately. If the dog exceeds the set border, the receiver will emit a beep signal (long intermittent beep) and on the receiver display for this dog starts flashing circle under direction indicator. To determine which dog exceeded the set border, switch between paired transmitters until you find the blinking circle.

### When you switch on this function, the receiver must be on good GPS signal:

1. In the main navigation panel select the number of the dog for which you want to activate the function FENCE.
2. Long press of the button **FENCE**.
3. Set the distance of an acoustic border using the arrows  / .
4. Press the  button briefly to return to do the main screen.

When you switch on the function, the lettering **FENCE** appears on the display. In the top line of the screen the lettering **FENCE** is displayed, if the function FENCE is activated for at least one collar, which you have paired with a receiver.

When the receiver starts to emit shorter intermittent beep – transmitter (collar) or receiver do not have a GPS or RF signal. This can occur if the dog goes for example inside the building (where there is no GPS signal), away from the RF signal, or when the accumulator in the transmitter is discharged.

**WARNING:** For the exact indication of the FENCE function is necessary to have a receiver on the best GPS signal, otherwise it will not indicate border crossing exactly (given by GPS accuracy).

**Note:** To use simultaneously the function FENCE and the tracking, pair one dog at two positions in the receiver. On one of the positions you then activate the FENCE and the other use for tracking.

**Switching off the function FENCE:**

1. Select the required dog number in the main navigation panel, for whom you want to switch off the function FENCE.
2. Press and hold the button **FENCE**.
3. Using the arrows **▲/▼** set **OFF**.
4. Briefly press **↶** to return to the main navigation panel.

**8.4 WAYPOINT – storing the receiver position**

The waypoint feature allows you to save the GPS coordinates of the location on which the receiver is now (the manual device). You can later navigate to the saved point. Up to 4 points (waypoints) can be stored in one receiver.

**Storing the waypoint:**

1. Hold the **CODE** button on the receiver for 2 seconds.
2. Use arrows **▲/▼** to select the position you want to store as the waypoint. The waypoint can be stored only to position 6 through 9. If the position is empty (no paired transmitter or any waypoint is in the position) the message **NO CODE** is shown on the display.
3. Hold the **BEEPER** button for 2 seconds – a message **PLACE SAVED** will be shown.
4. Push the button **↶** for return to the main screen.

To navigate to the stored waypoint, use arrows **▲/▼** selection on the main navigation panel to get to the given position.

**Deleting a waypoint:**

1. **Turn off all transmitters** (dog collars) near the receiver.
2. Hold the **CODE** button on the receiver for 2 seconds.
3. Use the arrows **▲/▼** to select the position you want to delete.
4. Hold the **CODE** button for 2 seconds – after some 10 seconds a message **NO CODE** will appear
5. Push the button **↶** for return to the main screen.

**WARNING:** If you store a waypoint in a position where you have a paired transmitter, this transmitter will be deleted from the receiver memory.

**8.5 BEEPER function**

The BEEPER function is mainly used by foresters/hunters to distinguish the intensity of movement or the presence of a dog near a wild boar. Modes 0, 1, 2, 5, 6 serve to inform you whether the dog is in motion or immobile (stalking the game). Modes 3, 4 serve to inform about the presence of a dog near a wild boar.

**Turning on:**

1. Turning on the transmitter (dog collar) – see chapter 6.3 *Turning the transmitter ON/OFF* on page 28.
2. On the main navigation panel use the arrows **▲/▼** to select number of the given dog.

3. In the **ON mode** move the target zones of the transmitter and receiver near to each other (just like during activation) and hold them together for 3 seconds – until an increasing tone is heard.
4. Move the receiver far from the transmitter.

If you activated the function properly, the message **BEEPER** will appear on the display of the receiver in the main navigation panel. In the top line of the display is shown the message **BEEPER**, if the function is activated in the transmitter of at least one dog.

### Setting the BEEPER function:

The BEEPER function must be set properly before the hunt.

1. On the receiver, select the number of the dog in the main navigation panel.
2. Hold the **BEEPER** button for long time– the display will show the first parameter for the setting  $\Pi$  – the mode.
3. Use the arrows  $\blacktriangle$  /  $\blacktriangledown$  to select the value.
4. To select other parameters, use repeated long hold of the button **BEEPER**. The adjusted parameters will appear in this order.
  - $\Pi$  (mode) – **setting the mode**
  - S (sensitivity) – **setting the sensitivity**
  - E (time) – **setting the time**
  - L (loudness) – **volume**
5. To return to the main screen push  $\hookrightarrow$ .

### Setting the mode – $\Pi$ :

In the device we can select from 7 modes:

Mode No.	indication		Hunt type
	motion	stationary	
0	Beeper text blinking	-	-
1	-	audio	Bird hunt
2	-	vibration	Bird hunt
3	-	audio	Wild boar hunt
4	-	vibration	Wild boar hunt
5	audio	-	-
6	vibration	-	-

**WARNING:** The audible and vibration indication can be set up for a maximum of 4 dogs, the visual indication is adjustable for 9 dogs. When the sound and vibration indicator is set, individual dogs can be identified by the number of beeps / vibrations (max. 4 beeps or vibrations) indicating movement / stationary position of the dog. If the acoustic and vibration indication is set for more dogs, vibration and sound are running simultaneously

Modes 3 and 4 are intended for hunting wild boar. The indication (sound or vibration) is triggered if the dog moves within the imaginary circle of the S-radius, which is given by the sensitivity setting (see the sensitivity setting chapter) for the time t, which is given by setting the time (time setting chapter).



### Setting the sensitivity – S:

- Setting the sensitivity for modes 0, 1, 2, 5, 6 serves for more precise recognition between moving/stationary dog.

**S-1:** Lower sensitivity – the dog is considered stationary even when it is moving a little bit.

**S-9:** High sensitivity – the dog is considered stationary only if it is absolutely still. Setting of sensitivity in mode 3, 4 serves to set the radius of the virtual circle.

- If the dog moves within this circle for certain time (t), the receiver will conclude the dog has found a wild boar.

Sensitivity - S	1	2	3	4	5	6	7	8	9
Radius - r [m]	5	10	20	30	35	40	45	50	60

The set radius of the virtual circle is approximate only – we need to respect the imprecision of the GPS position location.

### Setting of the time – t:

- Setting of time for modes 0, 1, 2, 5, 6 – the indication will begin if the dog remains in a given condition (moving/still) for a set time period. A delay in the status indication also depends from the set interval of location updates (see chapter 6.4 on page 28).

interval of updates [s]	3				6				9			
time t	1	2	3	4	1	2	3	4	1	2	3	4
indication delay [s]	7	10	13	16	10	16	22	28	11	20	29	38

The times in the table are estimates only.

- Setting of time for modes 3, 4 – the indication will start, if the dog remains in the virtual circle for time period t.

time t	1	2	3	4
Indication delay [s]	30	60	90	120



### Setting the volume of audio indications – L:



Audio indication can be adjusted in 3 levels. The set volume will affect the other functions too - FENCE.

## 8.6 CAR mode

Vehicle body and electronics can affect the function of the digital compass in the receiver - the direction of the dog being watched may not be displayed correctly. When CAR mode is activated, the direction to the dog will not be determined from the digital compass, but from changing the position of the GPS receiver.

### Turning the CAR mode on and off:

1. Push the  and the **BEEPER** button simultaneously for 2 seconds.
2. A message  will be shown on the display.

This mode will be deactivated in the same way – push both  and the **BEEPER** button simultaneously for 2 seconds. A message  will be shown on the display.

For proper operation, it is necessary to keep the RF receiver with its antenna in the direction of travel while moving (speed higher than 1 m/s). If the receiver is not in motion, the arrow will start blinking and show the last known direction.

---

## 9 MAXIMUM RANGE AND GPS ACCURACY

---

DOG GPS X20 can be used at distances up to 20 km (with free sight between transmitter and receiver). Maximum range and accuracy GPS, are influenced by a number factors - weather, terrain, vegetation etc.

In the densely wooded or built-up terrain will be the GPS position less precise and range will be much shorter - which is not caused by a defect in the device, but the rules of physics and technical capabilities (within the limits of European standards). If the GPS signal is poor, the distance will not be precise and it will change along with changing precision of the GPS receiver and transmitter.

### Securing maximum range and equipment precision:

- Check that the accumulator is sufficiently charged in the transmitter and receiver.
- Put the transmitter on the dogs neck properly - RF antenna facing up.
- Hold the receiver as high as you can, RF antenna up almost perpendicular to the ground (to be able to discern the direction on the display indicator).

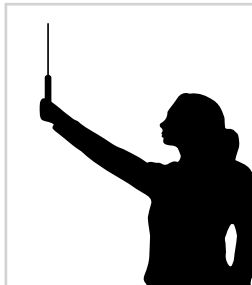

---

## 10 TROUBLESHOOTING

---

1. Read again this manual and make sure there is no problem due to a weak accumulator in the receiver or transmitter and if needed charge them.
2. If the accumulator is discharged quickly - accumulator life is near its end, replace it with a new one.
3. If the accumulator in the transmitter is discharged quickly adjust the position interval update to a lower level.
4. Check if the fault is caused by improper use.
5. Check the GPS signal of the receiver and transmitter in the open space.
6. If the transmitter and receiver are not communicating, try to pair those devices again - see Chapter: **7.4 Pairing of transmitter and receiver** on pg. 29.
7. In case of an inaccurate direction indication of the dog from you, re-calibrate correctly compass - see chapter: **7.5 Calibrating the digital compass** on pg. 30.
8. If the product does not indicate the exact position, calibrate the compass, locate the best GPS signal and make sure that the RF and GPS antenna on both devices are pointing to the sky.
9. If the problem persists, contact your dealer.

To clean your device DOG GPS X20 never use volatile substances, such as: thinner, gasoline or other cleaners. Use a soft, damp cloth and neutral cleaner.

If the device is not in use for longer period of time, charge the accumulator at least once a year.

After any replacement of battery in the transmitter (unscrewing the plastic cap on the transmitter cabinet) it is necessary to regularly check tightening of the screws of the transmitter cabinet. Tighten the screws with adequate force.

**WARNING:** If moisture ingress occurs in the transmitter cabinet due to improper tightening of the screws of the transmitter cabinet, warranty will be void.

If you use the GPS X20 transmitter in extreme terrain where excessive mechanical wear occurs, it is necessary to protect the transmitter. In case of excessive wear, the warranty repair will not be accepted.

#### Receiver (handheld device)

Power supply .....	accumulator Li-Pol 1900 mAh
The accumulator life on a single charge .....	up to 45 hours
Recharge time .....	3 hrs
Tightness .....	waterproof
Operating temperature .....	-10° C up to +50° C
Charging temperature .....	0° C up to +40° C
Weight .....	192 g
Dimensions .....	119 x 62 x 15 mm

#### Transmitter (collar)

Range .....	up to 20 km (free sight)
Power supply .....	accumulator Li-Pol 1900 mAh
The accumulator life on a single charge ..	up to 40 hours – position interval update 3 s up to 50 hours – position interval update 9 s
Recharge time .....	3 hrs
Frequency ( output) .....	869.525 MHz (500 mW)
Tightness .....	waterproof
Collar adjustable to size .....	cca 33 - 66 cm
Operating temperature .....	-10° C up to +50° C
Charging temperature .....	0° C up to +40° C
Weight .....	142 g
Dimensions .....	77 x 45 x 29 mm

**VNT electronics s.r.o.** provides a 2 year warranty on the **Dogtrace** products with respect to defects in material and workmanship under normal use and service from the date of the original purchase.

The limited warranty does not cover the following:

- straps
- direct or indirect risks during transportation of the product to the retailer
- mechanical damage of the product caused by user's negligence or an accident (eg. biting, breaking, impacts, excessive pulling of d-ring etc.)

1. The warranty period commences on the date of purchase. The sales receipt or your purchase invoice showing the date of purchase of the product, showing the serial number and date of purchase of the product, is the proof of the purchase date.
2. The warranty period does not apply to the reduction in the built-in battery capacity. The battery warranty period is 6 months from date of purchase.
3. The warranty does not cover damage resulting from:
  - a) improper installation or breach of instructions from the manufacturer's user guide
  - b) improper use of the product
  - c) improper storage or maintenance of the product
  - d) modification by a non authorized person, or a repair made without manufacturer's knowledge
  - e) natural disaster (wind, earthquake, lightning storm, etc.)
  - f) alternation of the goods made by the consumer if such an alternation resulted in a damage of the product
  - g) due to a consumer's mechanical damage
  - h) due to excessive wear of the product
  - i) due to other behaviour of the consumer that was in violation of these warranty terms or the instructions for use
4. The warranty can not be claimed if the goods is not completely paid, or when purchased on a sale.
5. The claimant is obliged to prove the defect and to enable the manufacturer to check the legitimacy of the product faults and assess the extent of the product faults. Otherwise is loosing the right arising from the manufacturer's responsibility for product defects.
6. Consumer demands arising from the producer's liability for defects are regulated in the general legislation.
7. It is required that all items being sent for a repair must be properly cleaned. Items deemed to be insufficiently cleaned will be returned unrepared to the customer. **Please do not include the strap or any other accessories if it is not a subject of the warranty.**
8. When sending the device to the service with a transport company, pack the goods adequately to protect it against a damage; it is recommended to keep the original packaging for this purpose. The producer is not responsible for a loss of goods during transport.

*The information contained in this manual may be subject to change due to developments without further notice.*

*Copying of this user guide is strictly prohibited without the prior written consent of **VNT electronics s.r.o.***