

Safety

Review the following safety precautions to avoid injury and prevent damage to this product on any products connected to it.

1. Use proper power cord. To avoid electric shock the grounding conductor must be connected to earth ground. Before using this product ensure that the product is properly grounded.
2. Connect the probe properly. The probe ground lead is at ground potential. Do not connect the ground lead to an elevated voltage.
3. Do not exceed the maximum ratings of this product when using it.
4. Do not operate this product with covers or panels removed.
5. Do not operate this product if there is damage to this product. Only qualified personnel should inspect it.
6. Keep product surfaces clean. Provide proper ventilation. Do not operate in wet conditions and an explosive atmosphere.

Beginning

I . General-Purpose

1. Categories of the products.

model	bandwidth	sampling rate	memory	interface	display
JC1202CA	200MHz	1GSa/s	4K	USB	color
JC1152CA	150MHz	1GSa/s	4K	USB	color
JC1152MA	150MHz	1GSa/s	4K	USB	mono
JC1152C	150MHz	250MSa/s	4K	USB	color
JC1152M	150MHz	250MSa/s	4K	USB	mono
JC1102CA	100MHz	1GSa/s	4K	USB	color
JC1102MA	100MHz	1GSa/s	4K	USB	mono
JC1102C	100MHz	250MSa/s	4K	USB	color
JC1102M	100MHz	250MSa/s	4K	USB	mono
JC1062CA	60MHz	1GSa/s	4K	USB	color
JC1062MA	60MHz	1GSa/s	4K	USB	mono
JC1062C	60MHz	250MSa/s	4K	USB	color
JC1062M	60MHz	250MSa/s	4K	USB	mono

JC1042MA	40MHz	1GSa/s	4K	USB	mono
JC1042M	40MHz	250MSa/s	4K	USB	Mono
JC1022M	25MHz	250MSa/s	4K	USB	mono

model	bandwidth	sampling rate	memory	interface	display
JC2202CA	200MHz	1GSa/s	4K	USB	color
JC2152CA	150MHz	1GSa/s	4K	USB	color
JC2152MA	150MHz	1GSa/s	4K	USB	mono
JC2152C	150MHz	250MSa/s	4K	USB	color
JC2152M	150MHz	250MSa/s	4K	USB	mono
JC2102CA	100MHz	1GSa/s	4K	USB	color
JC2102MA	100MHz	1GSa/s	4K	USB	mono
JC2102C	100MHz	250MSa/s	4K	USB	color
JC2102M	100MHz	250MSa/s	4K	USB	mono
JC2062CA	60MHz	1GSa/s	4K	USB	color
JC2062MA	60MHz	1GSa/s	4K	USB	mono
JC2062C	60MHz	250MSa/s	4K	USB	color
JC2062M	60MHz	250MSa/s	4K	USB	mono
JC2042MA	40MHz	1GSa/s	4K	USB	mono
JC2042M	40MHz	250MSa/s	4K	USB	Mono
JC2022M	25MHz	250MSa/s	4K	USB	mono

2. Mono/Color LCD display 320*240 resolution.
3. 20MHz bandwidth restrained.
4. 4k/Channel Memory Depth.
5. 50Gsa/s equivalent sample rate.
6. Automatic setup of the menu.
7. Storage of the waveforms and setups.
8. Delayed scan function, can display both the full view and details of the waveforms.
9. 20 automatic measurements.
10. Cursor measurements and automatic cursor tracking measurements.
11. Built-in FFT function digital filter, frequency counter.
12. Mathematic functions.
13. Trigger on edger, video, pulse width, external and power.
14. Menu with multiple languages.

II、 The front panel and operation instruction

Figure 1-1.1 shows the front panel of JC2000 series. Figure 1-1.2 shows the front panel of JC2000 series. Figure 1-2 shows the Front panel controls. The front panel has knobs and keys.

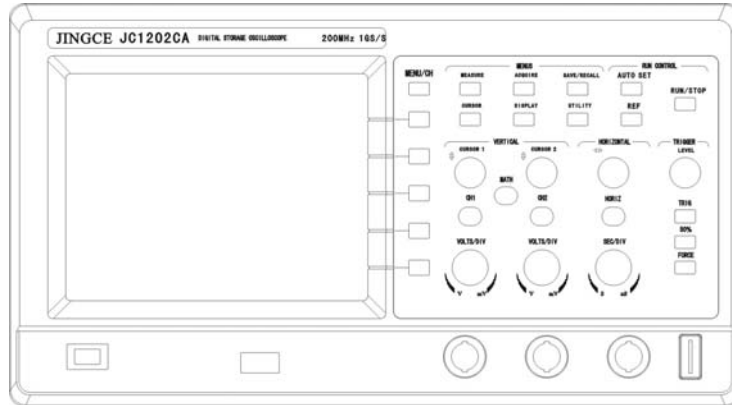

Figure 1-1.1 JC1000 series front panel of oscilloscope

The knobs are similar to the knobs on other oscilloscopes, such as POSITION、 LEVEL、 VOLTS/DIV.

The keys allow you to access to different kinds of the function menus and controls.

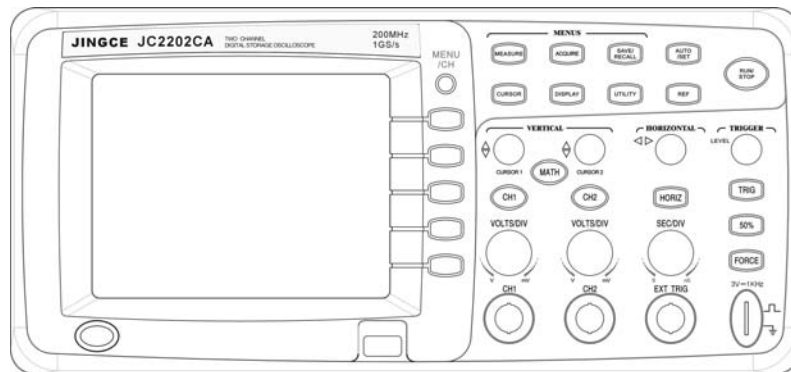
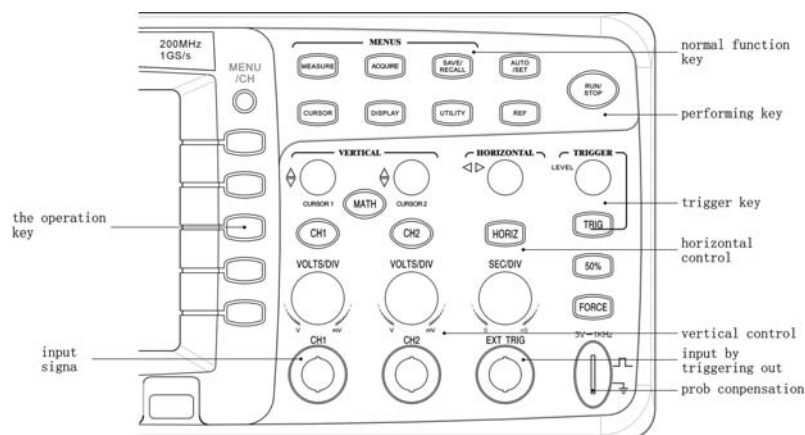

Figure 1-1.2 JC2000 series front panel of oscilloscope



1. Menu buttons: The 5 function buttons are on the right of the LCD screen. 2 methods are used to display the menu options in the oscilloscope, as shown in Figure 1-3.

- a. **Cycle list** The oscilloscope will set the parameter to a different value when pressing option buttons.
- b. **Action** The action type immediately occurs when pressing action option buttons.

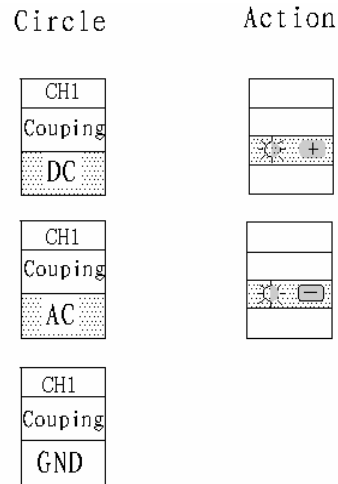

Figure1--3

III、 Function check

1. Turn on the instruments, a moment later the display shows that all self-tests passed, as show in Figure 1-4.

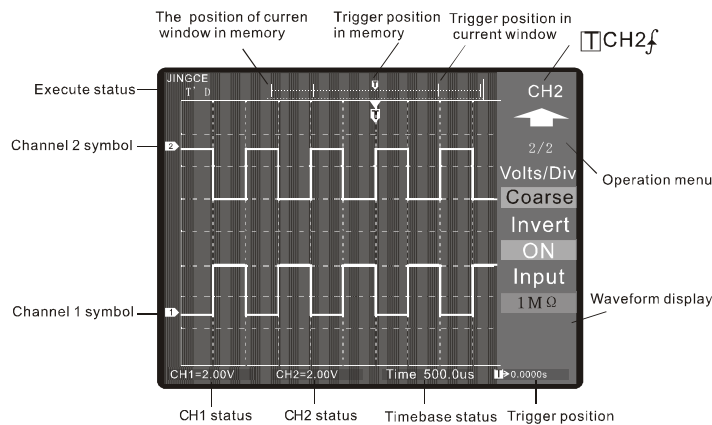

Figure 1-4. User Interface

2. Set the switch to 10× on the probe and connect the probe to channel 1 on the oscilloscope. To do this, align the slot in the probe connector with the key on CH 1 BNC, push to connect, and twist to the right to lock the probe in place, as shown in Figure 1-5.

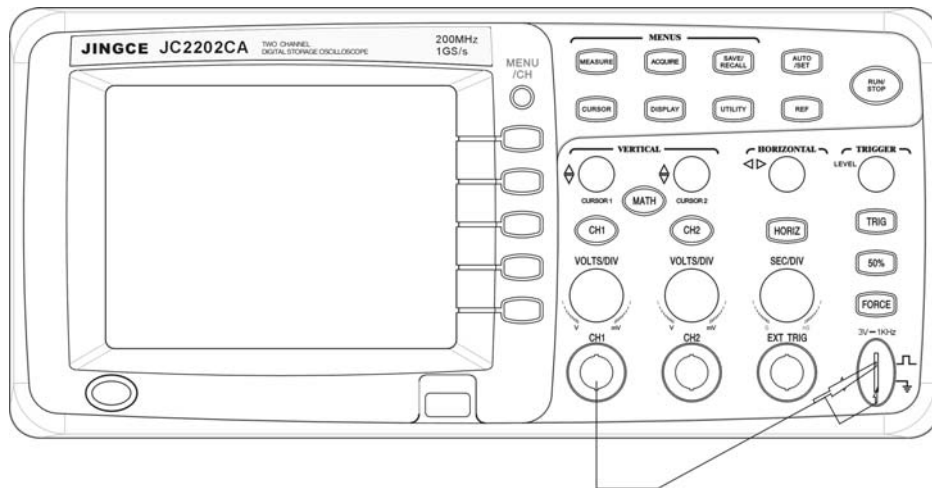

Figure 1-5 Probes Compensated

3. Attach the probe tip and reference lead to the **PROBE COMP** connector. Push the **AUTOSET** button. Within a few seconds, you could see a square wave in the display (3 V at 1 kHz peak-to-peak), as shown in Figure 1-6.

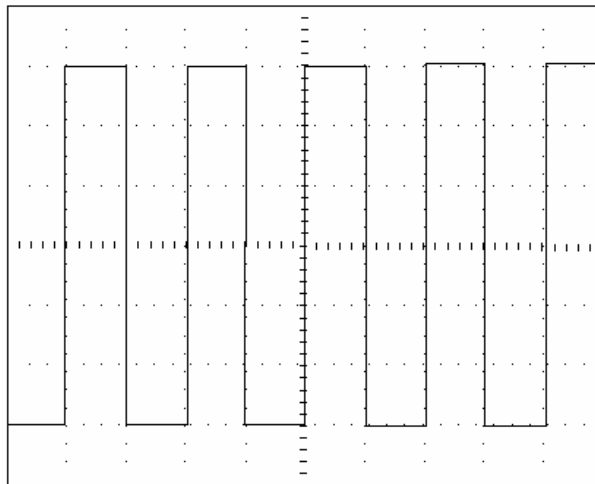
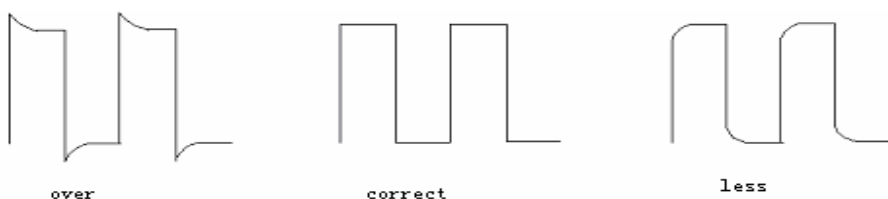

Figure 1-6 The wave of probes compensated

4. Using the same method to check CH2. Push the **MENU/CH OFF** button to turn off channel 1, push the **CH2** button to turn on channel 2, repeat steps 2 and 3.

IV. Probes compensation

1. Referring the steps above, attach the probe, and then press **AUTO/SET**
2. Check the shape of the displayed waveform, as shown in Figure 1-7.



3. If necessary, use a

nonmetallic tool to adjust the trimmer capacitor on the probe for the flattest square wave possible as displayed on the oscilloscope.

V. Automatic setup

The oscilloscope has an Auto feature that automatically sets up the oscilloscope to best display the input signal. Using Auto requires signals with a frequency greater than or equal to 50 Hz and a duty cycle greater than 1%.

1. Connect a signal to the oscilloscope.
2. Press AUTO/SET button, the waveform will be displayed automatically. If necessary, you can adjust manually **for your choice**.

VI. Vertical system

Figure 1-8 shows the vertical control zone.

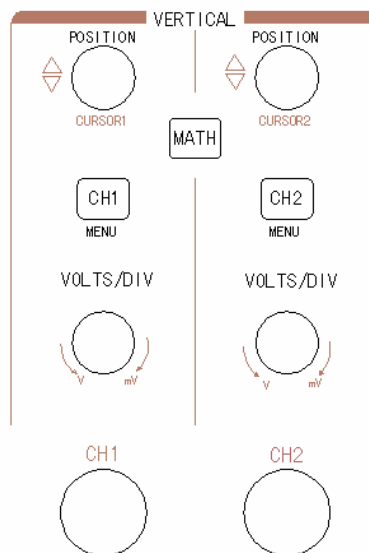

figure 1-8

1. POSITION-The POSITION knob moves the waveform vertically.
2. Volts/DIV-This knob changes the vertical step size increments, and it has fine and coarse status.
3. CH1, CH2, MATH-These are menu keys, and display the corresponding menu in the LCD. The 5 menu control keys provide the corresponding operation.

VII. Time Base System

Figure 1-9 shows the time base control zone.

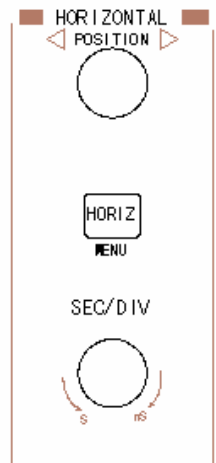

figure 1-9

1. POSITION-This knob adjusts horizontally signal on waveform window.
2. SEC/DIV-This knob changes the sweep speed from 2ns to 50s (the fastest speed is model dependent).
3. HORIZ-Press this key, you can enter or exit delayed scan, set the display to X-Y format and to Trig-Offset or Hold-off mode.

VIII. Trigger System

Figure 1-10 shows the trigger control zone.

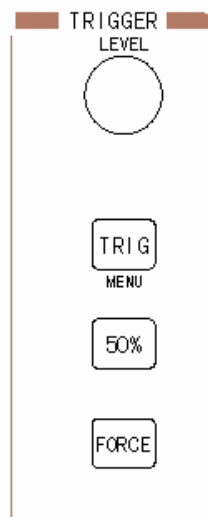

figure1-10

1. LEVEL

As you turn this knob, the trigger line is displayed following a sign. When moving the trigger line, the trigger level or percentage of the trigger will change.(When trigger coupling is AC or low frequency reject, the trigger level value will be displayed as percentage)

2. TRIG

Press this button, you can choose trigger type, trigger source, edge type, trigger mode and coupling. When you change your choice, the trigger type, slope, and source change in conjunction with the status on the top-right of the screen.

3. 50%

Press this button, the oscilloscope sets the trigger level to the center of the signal.

4. FORCE

Press this button to start an acquisition regardless of the trigger signal. It is mainly used in “normal” and “single” of the trigger mode.

Chapter 2 : Operating your oscilloscope

By now you get a brief understanding of JC2000 series oscilloscope with the VERTICAL、HORIZONTAL and TRIGGER groups of the front panel buttons. You should also know how to determine the setup of the oscilloscope by viewing the status bar. This chapter takes you through all groups of front panel buttons、knobs and menus. We recommend you perform all of the exercises in the following chapter so you become familiar with the powerful measurement capabilities of the oscilloscope.

I . Vertical system

Each channel has a corresponding operation menu. It is activated by pressing CH1 or CH2 key respectively. Each menu is divided into two pages and consists of seven selections.

Coupling: AC、 DC 、 GND. The corresponding indication in the status bar is ∞ 、 \perp

AC: AC blocks the DC component of the input signal.

DC: DC passes both AC and DC components of the input signal.

GND: disconnect the input signal.

BW limit

ON: Limit the channel bandwidth to 20MHz to reduce display noise.

OFF: To get use of full bandwidth, set "OFF".

Probe: Optional selections are 1X、 10X、 100X、 1000X. You can set this to match your probe attenuation factor to make the vertical scale readout correct.

Digital filter: Setup digital filter.

Volts/Div: Selects the resolution of the vertical SCALE knob. COARSE defines a 1-2-5 sequence while FINE changes the resolution by small steps between the COARSE settings.

Invert:

ON: Turn on the invert function

OFF: Restore to normal display of the waveform.

Input:

1M Ω : Set 1M Ω input impedance.

50 Ω : Set 50 Ω input impedance.

1、 Function description

In the following, CH1 is used as an example. CH2 is similar.

a、 Coupling: It determines how the input signal is coupled to oscilloscope. As Fig. 2-1.

AC: The DC component of the input signal is blocked. If the input signal is composed of small AC component and large DC component and you are only interested to view its AC component, this mode is proper. Typical usage is to observe the ripple of DC power source.

DC: Both AC and DC component of the input signal can be observed. You can measure the DC component of the input signal.

GND: The input signal is disconnected and Display is a line at ZERO position.

Status indication: The coupling mode is indicated at left bottom corner by following symbols:

AC ∞ 、 DC \dots 、 GND \perp .

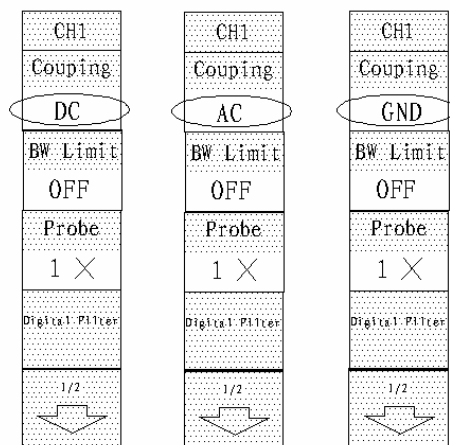

Figure 2-1

b、 Setup the channel bandwidth limit, as Fig.2-2 shows.

When disabled, the high frequency component of the input signal can pass through.

When enabled, the bandwidth of oscilloscope is limited to 20MHz, so the high frequency noise greater than 20MHz is blocked.

BW limit indication: When enabled, 'B' will be displayed at left bottom corner.

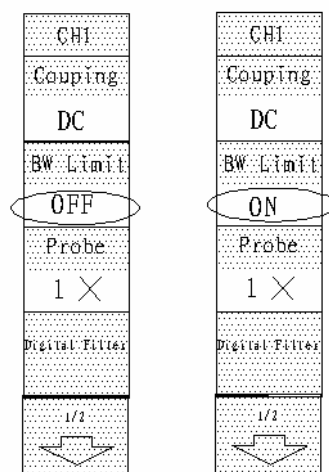

c、 Probe attenuation setting, see Fig.2-3.

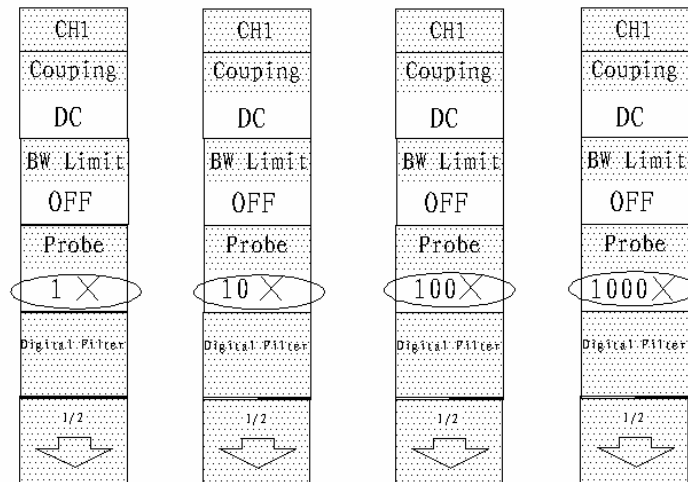

Figure2-3

Probe attenuation factor

Menu setting

When probe attenuation factor changes, the corresponding Volts/DIV indication is also changed. For example, 1:1 setting corresponds to 1V/DIV, then 10:1 setting changes to 10V/DIV.

d、 Volts/DIV setting, see Fig.2-5

The Volts/DIV control has COARSE or FINE configuration.

COARSE: It is the default setting of Volts/DIV, and it makes the vertical scaling in a 1-2-5 step sequence from 2mV/DIV to 5V/DIV.

FINE: This setting changes the vertical scale to small steps between the COARSE settings. It will be helpful when you need to adjust the waveform's vertical size in smooth steps. For example, if COARSE setting is 2mV, so the sequence of FINE setting will be 2.05mV、 2.10mV、 2.15mV、 ... etc.

e、 To invert a waveform

Invert turns the display waveform 180 degrees, as respect to the ground level. As Figure 2-4 shows.

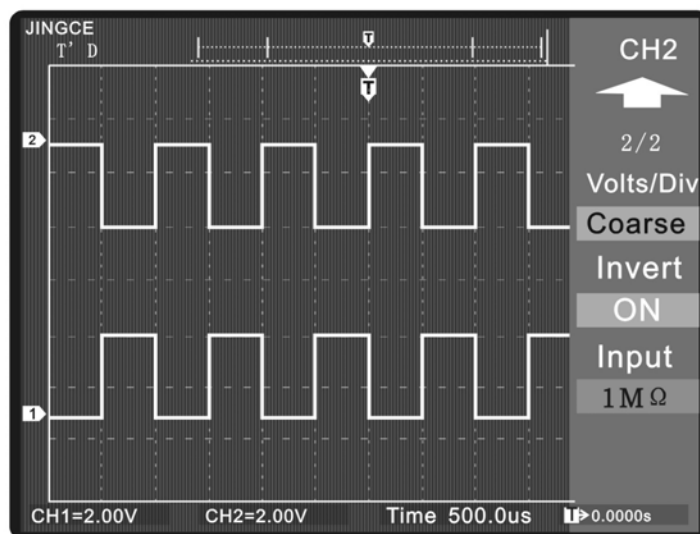

2-4

f、 Select input impedance, see Fig.2-5

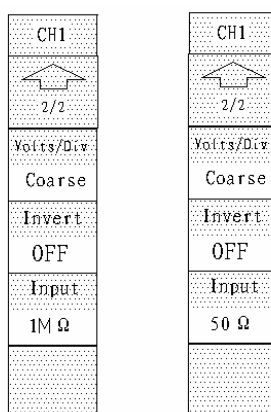

Figure 2-5

The input impedance of oscilloscope can be set to $1M\ \Omega$ or $50\ \Omega$ optionally. Setting $50\ \Omega$ makes it easy to measure high frequency signal or examine the characteristic of fast circuit, as well as to match the characteristic resistance of $50\ \Omega$ coaxial cable.

CAUTION: When $50\ \Omega$ is selected, **ALWAYS ENSURE** the input voltage at BNC does **NOT** exceed the maximum voltage ($5V_{rms}$) to avoid damaging channel input components.





In case $50\ \Omega$ is selected, a ' Ω ' is displayed at left bottom corner.

g、 Digital filter, see Fig.2-6 and Fig.2-7

Press CH1 → **Digital filter**, display the digital filter menu. Turn horizontal POSITION knob to set high and low limit of frequency.

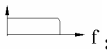
MENU	Setting	Comments
Digital Filter	ON	Turn on the digital filter
	OFF	Turn off the <u>digital filter</u>

Filter setting:

-  f: Low pass filter selected
-  f: High pass filter selected
-  Band pass filter selected
-  f: Band rejecting filter selected.

Up or low frequency limit adjustment: Turn the horizontal SEC/DIV or POSITION knob, the up limit or low limit can be changed respectively. (The function must be selected).

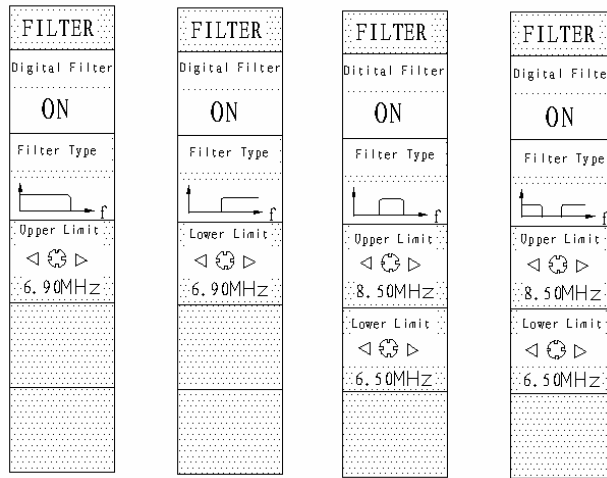

Figure 2-6



Figure 2-7

2、 Math functions

The mathematic functions include "add", "subtract", "multiply", "divide" and "FFT" for CH1 and CH2, as Fig.2-8 shows.

a、 Operation: Optional selections are $A+B$, $A-B$, $A \times B$, $A \div B$ and FFT. Here A、 B corresponds to the two signal sources respectively. It is selected by first pressing MATH to activate MATH function and then pressing F1 repeatedly to select desired operation.

b、 Invert: Set "ON" to invert the MATH waveform. Set "OFF" to restore normal waveform display.

c、 The amplitude of the MATH waveform can be adjusted by the vertical SCALE knob in a

1-2-5 step from 0.1% to 1000%. The scale will be displayed at the left bottom corner.

MATH	
Operate	
A+B	A-B A×B A÷B FFT
Source A	
CH1	CH2
Source B	
CH2	CH1
Invert	
OFF	ON

Figure 2-8

Using FFT

The FFT (fast Fourier transform) process mathematically converts a time-domain signal into its frequency components. FFT waveforms are useful in the following application:

- Measuring harmonic content and distortion in systems.
- Characterizing noise in DC power supplies.
- Analyzing vibration.
- Analyzing the characteristic of filter circuit or pulse response of the system

Fig.2-9 shows the FFT menu.

Display: Full screen: Display FFT waveform on full screen.

Split: Display FFT waveform on half screen.

Scale: V_{rms} : Set V_{rms} as vertical unit

dBV_{rms} : Set dBV_{rms} as vertical unit.

FFT	
Operate	
FFT	
Source	
CH1	CH2
window	
Rectangle	Hanning Hamming Blackman
Display	
Full Screen	Split
Scale	
V_{RMS}	dBV_{RMS}

figure 2-9

3. Using vertical POSITION knob

The vertical position of the waveforms can be changed by moving them up or down on the screen.

When you change the vertical position, the position message is displayed on the left bottom of the screen, such as POS: -1.20V. The message will disappear after few seconds.

3、 Using vertical Volts/DIV knob

The vertical scale of a waveform can be changed. If the probe is set to $1\times$ and the Volts/DIV is set to "COARSE", the waveform scales in a 1-2-5 step sequence from 2mV to 5V. If the Volts/DIV is set to "FINE", it scales to small steps between the coarse settings.

5、 Volts/DIV status is displayed on the status bar, such as CH1~500mV. Color LCD uses different color to display different waveforms.

二、 Horizontal system

1、 POSITION: The horizontal POSITION knob adjusts the horizontal position of all channels and math or REF waveforms. In other words, it changes the position of trigger point in the sampling memory. It can also be used to adjust the TRIGGER HOLDOFF. (The interval before the trigger circuit restart.)

2、 SEC/DIV: To adjust the time-base to a horizontal scale that suits your purpose, use the horizontal scale knob. As for JC2151C, the range of adjustment is from 50S/DIV to 2nS/DIV.

3、 Horizontal menu, as Fig.2-10.

TIME	
Delayed	
OFF	ON
Time Base	
Y-T	X-Y
< C >	
Trig-Offset	Holdoff
Trig-Offset	Holdoff
Reset	Reset

Fig.2-10

a、 Delayed scan: The Delayed Scan is a magnified portion of the main waveform window. You can use Delayed Scan to locate the horizontal expand part of the main waveform window for a more

detailed (high horizontal resolution) analysis of signal.

Use POSITION and SEC/DIV knob to change the horizontal position and size of delayed scan portion in the main waveform window.

Because the screen is split into two parts vertically in the Delayed Scan mode, the amplitude of the display waveform reduce to half of the original or more, so the Volts/DIV changes accordingly.

b、Trigger offset: Adjust horizontal position in memory by use of the POSITION knob. The adjusted time message is displayed on the left bottom of the screen, such as $T \rightarrow 200.0000\text{ns}$. Pressing Trigger offset reset key can reset it to $T \rightarrow 0.000000\text{ns}$ which corresponds to the middle point of the screen.

c、Trigger HOLDOFF: Trigger HOLDOFF can stabilize waveform. Hold-off time is the oscilloscope's waiting period before starting a new trigger. During the hold-off oscilloscope will not trigger until hold-off ends. The Hold-off time can be adjusted from 100ns to 1.5s. By pressing Hold-off reset, the Hold-off time resets to its 100ns minimum value.

d、X—Y format.

This format compares the voltage of two waveform records point by point. It is useful for studying phase relationship between two waveforms.

This format only applies to channel 1 and 2. Choose X—Y display format to display channel 1 in the horizontal axis and channel 2 in the vertical axis. The oscilloscope uses the un-triggered sample acquisition mode and data displays as dots. The sampling rate can vary from 4KS/s to 100MS/s, and the default sampling rate is 1MS/s. See Fig.2-11.

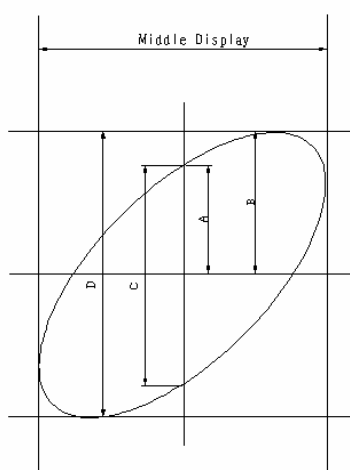

Figure 2-11

三、Trigger system

The trigger determines when the oscilloscope starts to acquire data and display a waveform. When a trigger is set up properly, it can convert unstable displays or blank screens into meaningful waveforms.

Traditional analog oscilloscope can only display waveforms after the trigger point (Satisfying trigger condition). Modern digital oscilloscope overcomes this restriction. When the oscilloscope starts to acquire a waveform, it collects enough data so that it can draw the waveform to the left of the trigger point. The oscilloscope continues to acquire data while waiting for the trigger condition to occur. After it detects a trigger, the oscilloscope continues to acquire enough data so that it can draw the waveform to the right of the trigger point. Because digital oscilloscope can observe the signal part before the trigger point, it is very useful in the research of component defects or relay contacts.

- 1、 LEVEL: use the knob to set the trigger level.
- 2、 50%: The instant executing button sets the trigger level to the vertical midpoint between the peaks of the trigger signal.
- 3、 Force: Starts an acquisition regardless of an adequate trigger signal. This button has no effect if the acquisition is already stopped.
- 4、 MENU: The button that activates the trigger control menu.
 - a、 Edge: Edge trigger can be used in analog and digital circuit analysis. An edge trigger occurs when the trigger input passes through a specified voltage level in the specified slope direction (rising or falling). See Fig. 2-12.

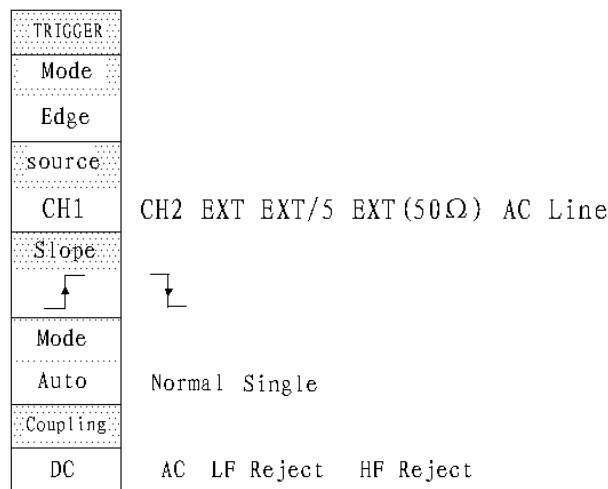

Figure 2-12

- b、 Video: Use video trigger on fields or lines for standard video signals. See Fig.2-13.
- c、 Pulse: Use this trigger type to catch pulses with certain width. See Fig.2-16.

■ Setting for edge Trigger

The **SLOPE** and **LEVEL** controls help to define the trigger. The **SLOPE** control determines whether the oscilloscope finds the trigger point on the rising or the falling edge of the signal.

※ Source

CH1: Selects CH1 as the trigger signal.

CH2: Selects CH2 as the trigger signal.

EXT: Select EXT TRIG as the trigger signal.

EXT/5: Selects EXT TRIG/5 as the trigger signal.

AC line: Selects power line as the trigger signal.

EXT (50 Ω) : Select EXT TRIG(Input impedance is set to 50 Ω) as the trigger signal.

※ Slope

Rising: Trigger on the rising edge.

Falling: Trigger on the falling edge.

※ Mode:

Auto: Acquire waveform even no trigger occurred.

Normal: Acquire waveform when trigger occurred.

Single: When trigger occurs, acquire one waveform, then stop.

※ Coupling:

DC: Apply all components of the trigger signal to the trigger circuitry.

AC: The DC component and AC components($\leq 5\text{Hz}$) of the trigger signal are blocked.

LF Reject: Permit the high frequency components of the trigger signal to pass through. The components (Below 8 kHz) of the trigger signal are attenuated.

HF Reject: Permit the low frequency components of the trigger signal to pass through. The components (Above 150 kHz) of the trigger signal are attenuated.

■ Setting for video trigger

Choose video triggering to trigger on fields or lines of NTSC、PAL、or SECAM standard video signals, as Fig.2-13. Trigger coupling presets AC.

※ Source:

CH1: Selects CH1 as the trigger signal.

CH2: Selects CH2 as the trigger signal.

EXT: Select EXT TRIG as the trigger signal.

EXT/5: Selects EXT TRIG/5 as the trigger signal.

AC line: Selects power line as the trigger signal.

EXT (50 Ω) : Select EXT TRIG(Input impedance is set to 50 Ω) as the trigger signal.

※ Polarity

- Normal: Trigger on the negative edge of the sync pulse.
- Inverted: Trigger on the positive edge of the sync pulse.

※ Sync:

- All lines: Trigger on all lines.
- Line Num: Trigger on an appointed line(Use the LEVEL knob to select the desired line number), as Fig.2-14.
- Odd field: Trigger on odd field.
- Even field: Trigger on even field, as Fig.2-15.

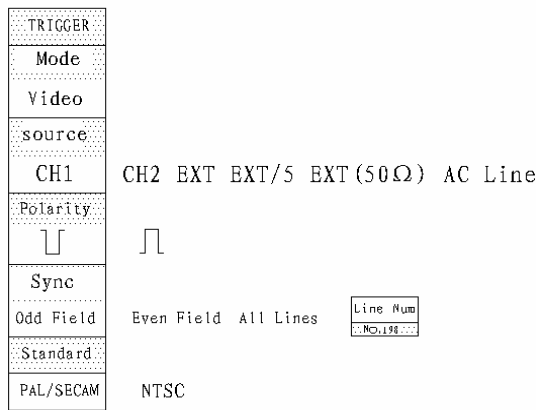

Figure 2-13

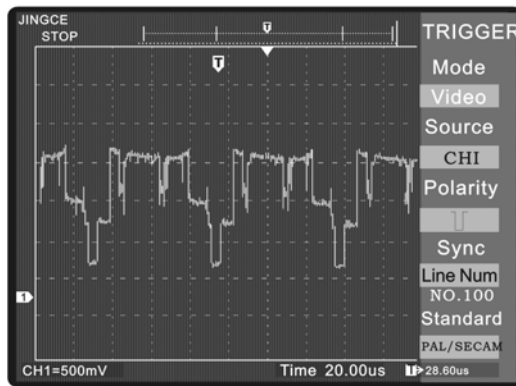

Figure 2-14 Synchronized on line 100

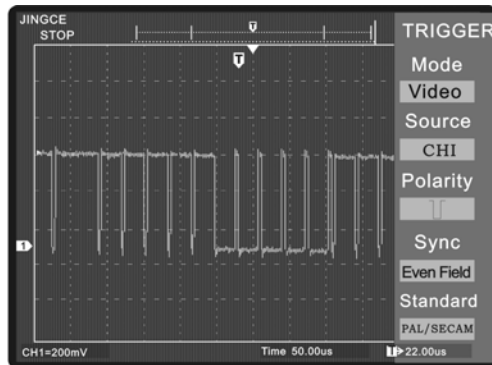
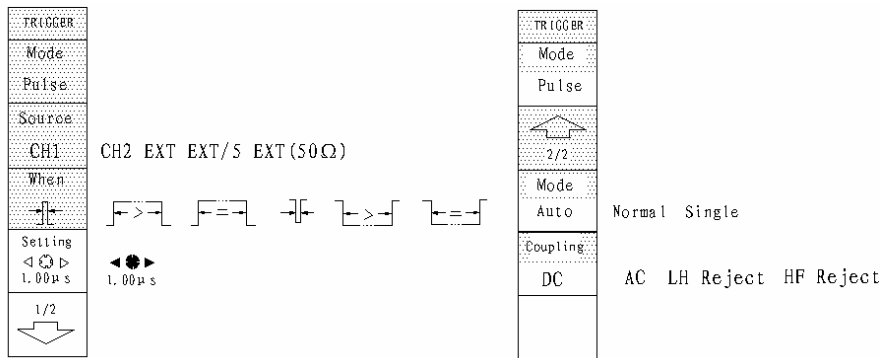

Figure 2-15 Field synchronization

■ Setting for pulse width trigger

Pulse trigger occurs according to the width of pulse, which makes it easy to observe some complicate pulse combination.



※ Source: The source of pulse trigger can select each of the following: CH1、CH2、EXT、EXT/5、EXT (50 Ω).

※ When: Set the trigger condition

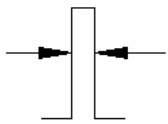

Positive pulse width less than

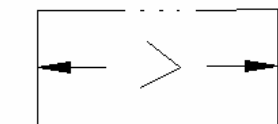

Positive pulse width greater than

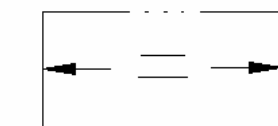

Positive pulse width equal to

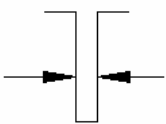

Negative pulse width less than

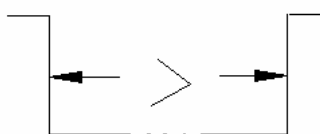

Negative pulse width greater than

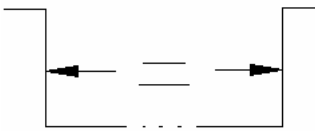

Negative pulse width equal to

※ 1.00 μs Setting: Adjust pulse width to desired value.

By pressing the corresponding function key, the color of the symbol  1.00 μs reversed, then you can turn the horizontal POSITION knob to change the pulse width.

- ※ Mode: There are three trigger modes: Auto、Normal、Single. Their function is the same as EDGE trigger.
- ※ Coupling: Includes DC、AC、HF Reject and LF Reject. Their function is the same as EDGE trigger.

四、Sampling system

The ACQUIRE button for sampling system is at the MENU area. Pressing ACQUIRE button, the setup menu of sampling system appears, as Fig.2-17.

There are four choices for the operating mode of acquisition:

- Normal: Fast sampling in a regular interval to construct waveforms based on trigger.
- Average: Multiple reconstructed waveforms are averaged to generate a waveform for display. In this case, noise is greatly reduced to recover the useful message, which is very useful in biological and medical field.
- Analog: Analog display mode, the brightness is corresponding to the possibility that data appear. The more often, the brighter.
- Peak detect: Multiple waveforms are acquired to detect and display the envelopes of the waveforms. The noise becomes greater in this mode.

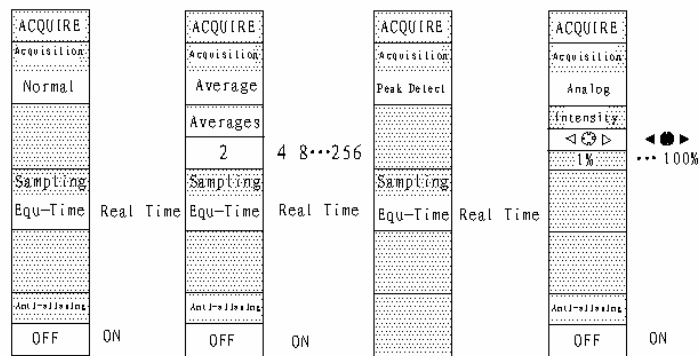

Figure 2-17

Note:

● Scan: When observing slow signal, if SEC/DIV is lower than 50ms/DIV and trigger mode is set "AUTO", oscilloscope is working at so-called SCAN mode, waveform is displayed rolling from left to right, while horizontal POSITION and trigger control has no effect. As to examine slow signal, coupling of the input channel should be set at "DC".

● In analog mode, when brightness is selected, it can be adjusted from 1% to 100% by horizontal POSITION knob. Available lowest time-base is 20ms/DIV.

● Anti-aliasing: If the sampling speed of the oscilloscope is not fast enough, the waveforms cannot be reconstructed accurately. Instead, aliasing occurs. Theoretically, the maximum frequency recoverable for the oscilloscope is half of the sampling frequency. When anti-aliasing is enabled, the artificial effect may be removed.

● Real-time or Equivalent: In real-time mode, each trigger leads the oscilloscope to sample a complete waveform, so non-periodical or one-shot signal can be captured. If the sampling speed is over 20ns, the oscilloscope automatically interpolate data to display waveforms. On the contrary, equivalent mode assumes that the input signal is periodical, it reconstruct a waveform based on many triggers. In equivalent mode, horizontal resolution is up to "20ps", i.e. 50GS/s equivalent sampling speed.

五、 Display system

The **DISPLAY** button is at the MENU area. Pressing **DISPLAY** button, the setup menu of display system appears.

■ Display type

Vector: The points between two adjacent sampling points are interpolated based on linear or $\sin(x)/x$ function. $\sin(x)/x$ is used in real-time sampling mode when SEC/DIV is over 20ns/DIV.

Dot: Sampling data is displayed straightly.

■ Grid:

- a、 Display both grids and coordinates on the screen
- b、 Turn off the grids
- c、 Turn off the grids and coordinates.

■ Press  to increase display contrast; Press  to decrease display contrast.

Persist:

Infinite: The sample points remain displayed until turn the persistence "OFF"

OFF: Waveform display is refreshed in high rate.

■ Menu Display: Optional selections are: 1s、2s、5s、10s、20s、Infinite. The menu will be hidden

according to the time after last key pressing.

■ Screen:

Normal: Set to normal mode.

Invert: Set to invert color display mode.

六、 Save and recall waveforms or setups.

The **SAVE/RECALL** button is at the MENU area. Pressing **SAVE/RECALL** button, the **SAVE/RECALL** menu appears, as Fig.2-18.

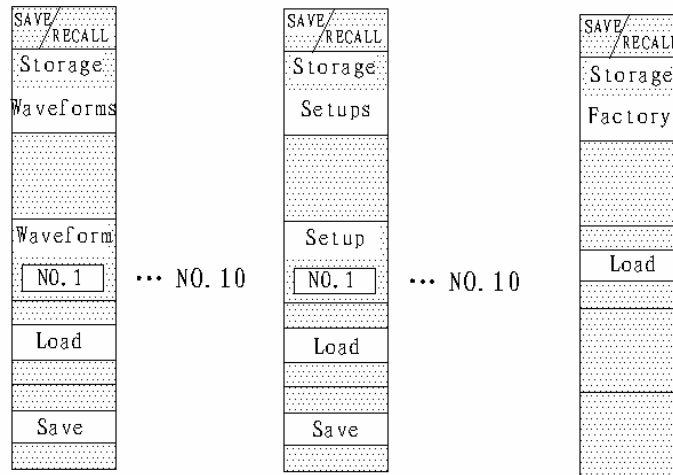

Figure 2-18

Menu	Settings	Comments
Storage	Waveforms	Store or recall waveforms
	Factory	Recall factory setups
	Setups	Store or recall instrument setups
Waveform	No. 1	
	No. 2	
	No. 3	Select storage location of waveform
	...	
Setup	No. 10	
	No. 1	
	No. 2	
	No. 3	Select storage location of setup
Load	...	
	No. 10	Recalling of Stored documents
Save		Storage of waveform data Importer www.hadex.cz

■ **Factory Setup:** The oscilloscope is setup for normal operation when it is shipped from factory. You can recall the factory default setup any time you want to operate the oscilloscope.

■ **Waveform:** You can save up to 10 waveforms of two channels and 10 settings in the nonvolatile memory of the oscilloscope and overwrite previously saved contents as needed. By default, the oscilloscope saves the setup each time it is powered off. The oscilloscope automatically recalls this setup the next time it is powered on.

■ **Load:** The stored waveforms, setups and factory setup can be recalled out.

■ **Save:** Store existing waveforms or setups.

Note:

The **Save** stores not only the waveforms, but also the current settings of the oscilloscope.

七、Auxiliary function **UTILITY**

Press **UTILITY** button, then enter the **UTILITY** menu.

1、Interface setup

RS-232 baud rate: If ***** is displayed, it means that RS-232 communication is not available. Baud rate can be from 300 to 38400.

GPIB address: If ***** is displayed, it means that GPIB function is unavailable. Address can be 0、1、2、..... 30.

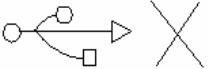
USB interface:  Disconnected

 Connected

2、Sound

 Enable beep sound for key press

 Disable beep sound for key press

3、Counter:

ON/OFF: Turn on/off frequency counter.

4、Language: Select language for menu and system message display. Such as simplified Chinese、traditional Chinese、English、Korean、Japanese... etc.

5、In the second page, other functions such as **PASS/FAIL**、**Waveform recorder**、**Auto calibration** and **Auto test** can be activated.

■ **PASS/FAIL**

Through detecting whether waveforms are in the preset area, PASS/FAIL module monitors the change of

input signal continuously. See Fig.2-19

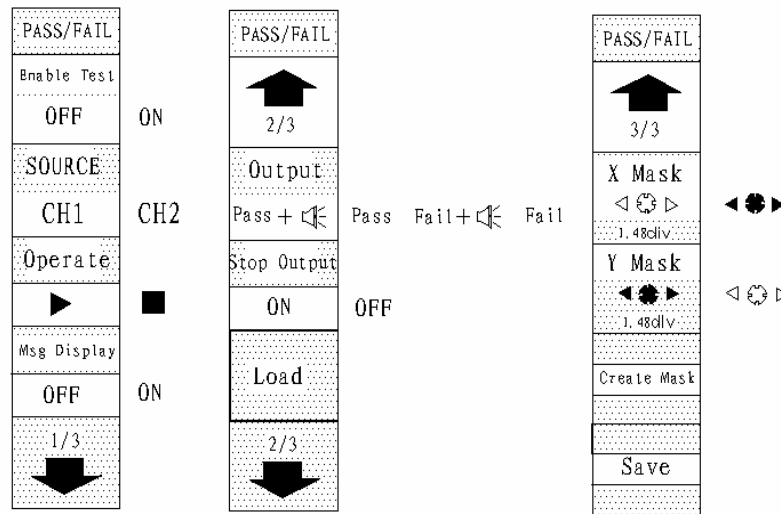

Figure 2-19

● 1/3 Menu:

Enable Test: On/Off: Turn on/off Pass/Fail test
 Source: CH1/CH2: Select Pass/Fail test on CH1/CH2
 Operation:

▶: Pass/Fail test stopped, press to run
 ■: Pass/Fail running, press to stop

Msg Display: On/Off: Turn on/off Pass/Fail information display

● 2/3 Menu:

Output:

Fail:Output when fail condition detected

Fail [beep icon] + : Output and beep when fail condition detected

Pass:Output when pass condition detected

Pass [beep icon] + : Output and beep when pass condition detected

Stop On Output:

On: Stop test when output occurs

Off: Continue test when output occur

Load:Load a pre-defined test mask

● 3/3 Menu:

X Mask:Set horizontal clearance to the waveform,(0.04div to 4.00div). When the item is activated, it can be adjusted by turning horizontal POSITION knob.

Y Mask:Set vertical clearance to the waveform,(0.04div to 4.00div). When the item is activated, it can be adjusted by turning horizontal POSITION knob.

Create Mask:Create a test mask according to the above clearance.

Save:Store created test mask.

Note:In X-Y mode, Pass/Fail function is unavailable.

Waveform recorder

Waveform recorder can record output waveform from CH1 and CH2 through setting up time interval between frames, with a maximum record length of 1000 frames. User can analysis waveform saved by playback. There are four kinds of recorder models: Record, Play back, Storage, Off. Figure 2-20

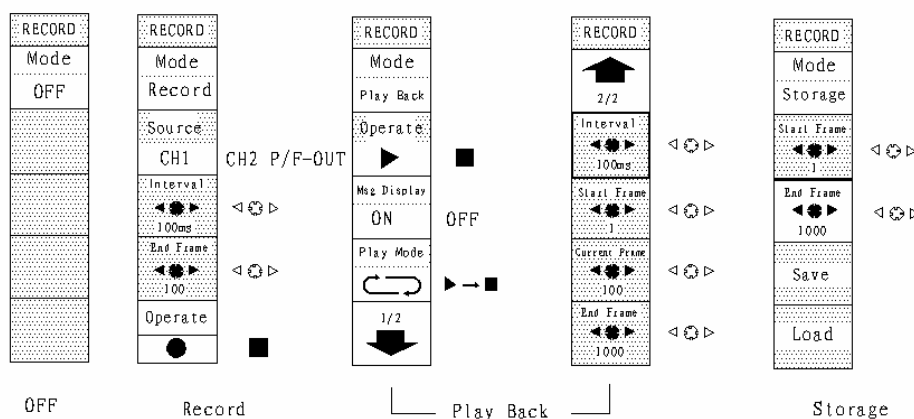

Figure 2-20

Off: Turning off all recorder function

Recorder: 1. Selecting RECORD MODE

2. Selecting record source channel CH1 or CH2
3. Setting time interval between frames from 1.00ns to 1000ns
4. Setting number of record frames from 1 to 1000
5. Selecting ● to start recording or ■ to stop recording in the OPERATION menu.

Play back:



1. Selecting ■ to start playback or ► to stop in the OPERATION menu
2. Selecting ON to display recorder information or OFF to turn off recorder information in the MSG DISPLAY menu
3. Selecting ↻ to set circular play mode or ► → ■ to set single time play mode in the PLAY MODE menu
4. Selecting ◀▶ to set time interval from 1.00ms to 20s between frames in the INTERVAL menu
5. Selecting ◀▶ to set start frame from 1 to 1000 in the START FRAME menu
6. Clicking ◀▶ to select current frame from 1 to 1000 to be played in the CURRENT

FRAME menu

7. Selecting  to set end frame from 1 to 1000 in the END FRAM menu

The RUN/ STOP button can also control playback run/stop

Storage:

1. Selecting SAVE menu to store the waveforms between start frame to end frame
2. Selecting LOAD menu to recall the saved waveforms from non-volatile memory
3. Selecting  to set first frame to be saved
4. Selecting  to set last frame to be saved

Self- Test

Press SELF-TEST menu to choose System Info or Screen Test

1.Screen test: Press this soft button to run Screen Test program. Follow the prompt message on the screen “ Press ‘RUN’ key to continue the Test ” . The screen of JC2000series turns black or white in sequence (Mono) and the screen of JC2000 series turns red, green and blue in sequence (Color) when keep pressing the RUN/STOP button. You could check the screen for display failures.

2.System info: Press this soft button to display the basic information of oscilloscope.

Self-adjustment

Several months after the instrument has been working, user can amend it by pressing button to come into self-adjustment interface. Selecting RUN/STOP to start or end.

Attention: Any input terminal must not be shorted and connect to any signal

八、 How to measure automatically

The AUTO MEASURE button is in the menu area. You are able to choose the source signal from CHI or CH2 and the method of time measurement and voltage measurement. All the measurement parameter can be on or off on the screen, and deleted all clearly from it. Figure 2-21.

VOLTAGE MEASUREMENT

JC2000 series provide over ten measurement function , including Vpp , Vmax , Vmin , Vavg , Vamp ,Vtop , Vbase , Vrms ,Overshoot , Preshoot . Figure 2-22.

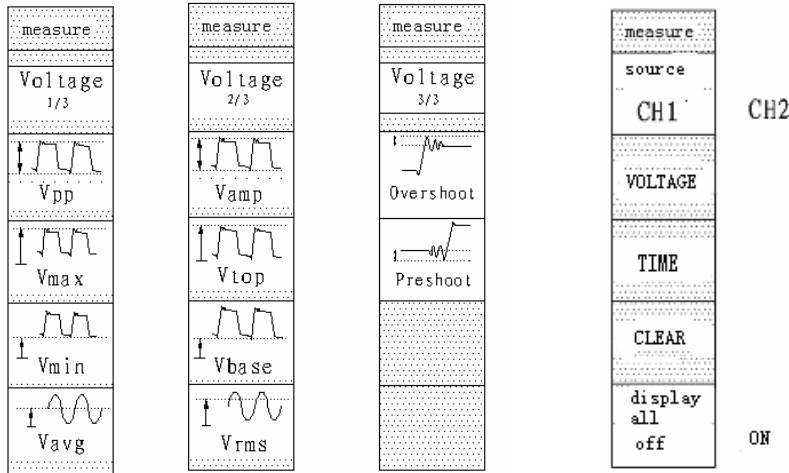



Figure2-22

FIGURE 2-21

TIME MEASUREMENT

JC2000 series provide over ten measurement function , including Freq , Period , Rise time , Fall time , +Width , -Width , +Duty , -Duty , Delay1 →  (delay the time rising) , Delay1 →  (delay the time falling) . Figure 2-23 .

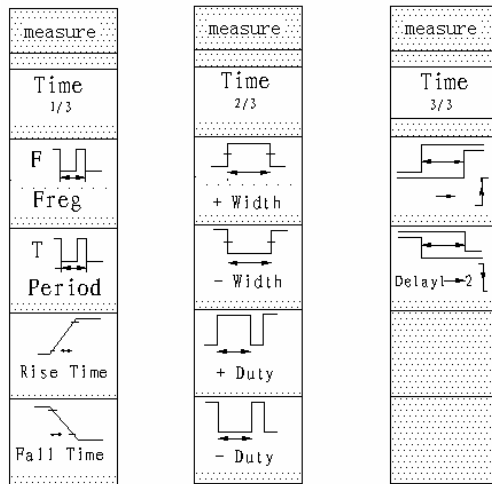

Figure 2-23

The results of the automatic measurements will be displayed the bottom of the screen, where no more than three parameters can be displayed at the same time, moving automatically toward left and being deleted by DELECTING MEASUREMENT button.

Press DISPLAY ALL to ON button to display 18 results of measurements in the center of the screen, if the data is displayed as“*****”, which means the parameter cannot be measured at present.

THE DEFINITION OF THE VOLTAGE PARAMETER FIGURE 2-24

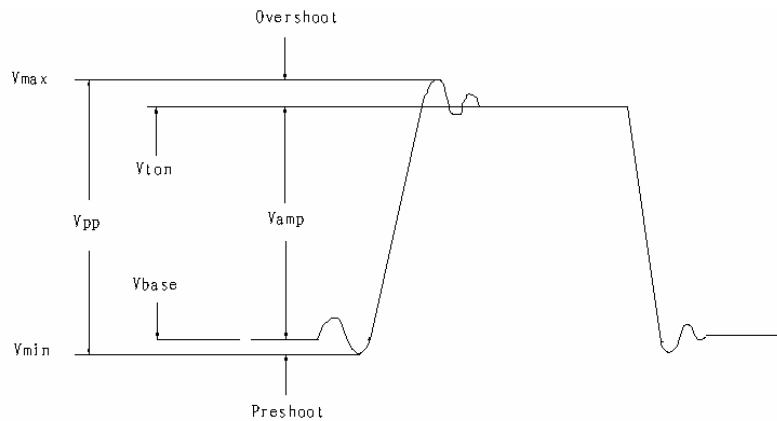

Figure2-24

Vpp : Peak-to-peak Voltage

Vmax: The maximum amplitude. The most positive peak voltage to GND in the waveform.

Vmin: The minimum amplitude. The most negative peak voltage to GND in the waveforms.

Vam: The voltage Vtop and Vbase of a waveform.

Vtop: The voltage to GND of the top of the waveform

Vbase : The voltage to GND of the bottom of the waveform

Overshoot: Defined as $(V_{max} - V_{top}) / V_{amp}$

Preshoot: Defined as $(V_{min} - V_{base}) / V_{amp}$

Vaverage: The average of the signal

Vrms : The effect value of the signal

THE DEFINITION OF THE TIME PARAMETER FIGURE 2-25

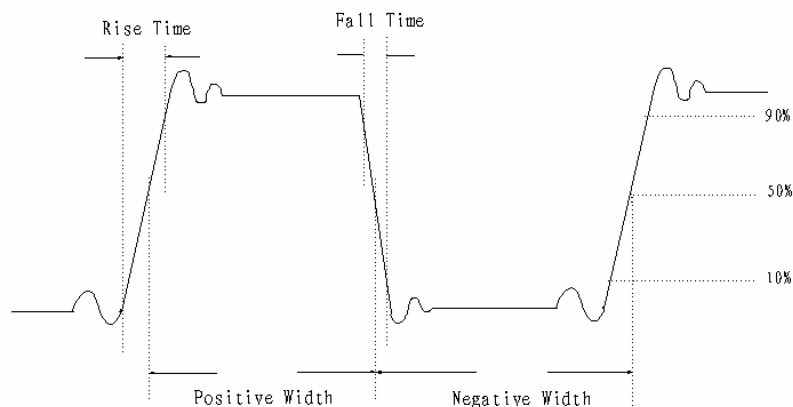



Figure2-25

Rise time: Time that the leading edge of the first pulse in the waveform takes to rise from 10% to 90% of its amplitude.

Fall time: Time that the falling edge of the first pulse in the waveform takes to fall from 90% to 10% of its amplitude.

Positive width: The width of the first positive pulse in 50% amplitude points.

Negative width: The width of the first negative pulse in 50% amplitude points.

Delay 1 → : The delay between the two channels 1.2 at the rising edge.

Delay 1 → : The delay between the two channels 1.2 at the falling edge.

+Duty: +Duty Cycle, defined as +Width/Period

-Duty: -Duty Cycle, defined as -Width/Period

How to measure with cursors

The cursor measurement has three modes: Manual, Track and Auto measure.

1. Manual: In this model, the screen displays two parallel cursors. You can move the cursors to make custom voltage or time measurements on the signal. The values are displayed on the boxes below the menu. Before using cursors, you should make sure that you have set the signal source as the channel for measuring.

2. Track: In this mode, the screen displays two cross cursors, the cross cursor set the position on the waveform automatically. You could adjust cursor's horizontal position on the waveform by turning the horizontal POSITION knob in conjunction with the cursor. The oscilloscope displays the values of the coordinates on the boxes below the menu.

3. Auto Measure: This mode will take effect with Automatic Measurements. The instruments will display cursors while measuring parameters automatically. These cursors demonstrate the physical meanings of these measurements.

Operations of Cursor Measurements

to do manual mode Cursor Measurements, follow these steps figure 2-26

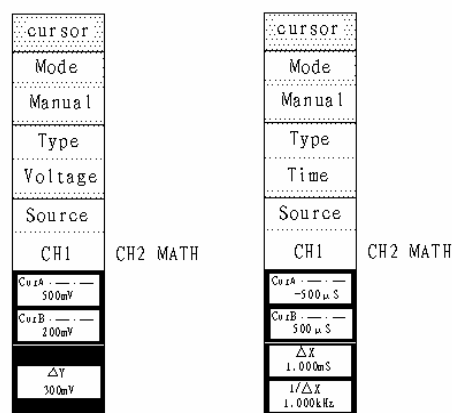

Figure2-26

(1) . Select the Manual mode for cursor measurement by pressing soft button as :CURSOR→ Mode→Manual.

(2) . Select channel Source for measurements by pressing soft button as:

CURSOR→Source→CH1, CH2 or MATH

(3) . Select the cursors type by pressing soft button as CURSOR →Type→Voltage or Time.

(4) . Move the cursors to adjust the increment between the cursors: Turn the vertical POSITION knob to move cursor A or B vertically; Turn the vertical POSITION knob to move cursor A or B horizontally.

(5) . To gain measurement value:

Display Cursor 1 (time cursor centered around the midpoint of screen; voltage cursor centered around channel ground level)

Display Cursor 2(same as above)

Display horizontal space between cursor 1 and 2 (ΔX) : Time between cursors

Display ($1/\Delta X$) , units in Hz, KHz, MHz, GHz

Display vertical space between cursor 1 and 2 (ΔY) : Voltage between cursors

to do Track mode Cursor Measurements, follow these steps: figure 2-27

cursor		
Mode		
Track		
CursorA		
CH1	CH2	None
CursorB		
CH1	CH2	None
Cur-Ax	Cur-Bx	
-500 μ S	500 μ S	
Cur-Ay	Cur-By	
500mV	200mV	
ΔY	ΔX	
300mV	1.000mS	
	$1/\Delta X$	
	1.000kHz	

Figure2-27

(1) .Select the Track mode for cursor measurement by pressing soft button as : CURSOR---Mode---Track.

(2) . Select channel Source for Cursor A and Cursor B by pressing soft button as: CURSOR→Cursor A or Cursor B→CH1, CH2 or None.

(3) . Move the cursors to adjust the horizontal positions of the cursors : Turn the vertical POSITION knob to move Cursor A or B horizontally .

(4) . To gain measurement value:

Display Cursor 1 (time cursor centered around the midpoint of screen ; voltage cursor centered around channel ground level)

Display Cursor 2(same as above)

Display horizontal space between cursor 1 and 2 (ΔX) : Time between cursors

Display ($1/\Delta X$) , units in Hz, KHz, MHz, GHz

Display vertical space between cursor 1 and 2 (ΔY) : Voltage between cursors

To do Auto mode measurements. Figure 2-28

There will be no cursor display if no parameter were chosen in MEASURE menu .This oscilloscope could move cursor automatically to measure 20 parameters in MEASURE menu .

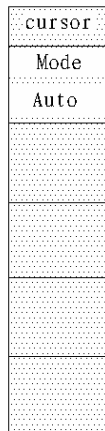
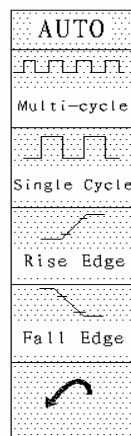

Figure2-28

十、 How to use instant execute buttons — AUTO , RUN AND STOP

The AUTO features automatic adjustments to produce a observable display of input signal . figure 2-29



Multi-cycle: To ^{figure2-29}veral multicycle waveform automatically on the screen

Single-cycle: To display single cycle waveform automatically on the screen.

Rise edge: To display the waveform's rising edge and measure its rise time automatically

Fall edge : To display the waveform's falling edge and measure its fall time automatically

Cancel  : To cancel all Auto Set actions

RUN/STOP: Run or Stop waveform acquiring

In STOP status, the volts/div and horizontal time base can be adjusted in a fixed limit.

Auto-set functions

After the AUTO is pressed the oscilloscope is configured to the following defaults.

Display format: Y- T

Sampling mode: Equal – time

Acquire mode: Normal

Vertical coupling: Adjust to AC or DC according to the signal

Vertical “V/div”: Adjust to the right position according to the signal

Volts/Div: Coarse

Bandwidth limit: OFF

Signal Invert: OFF

Horizontal position: Center

Horizontal “S/div”: Adjust to the right position according to the signal

Trigger type: Edge

Trigger source: measure the channel with input signal automatically

Trigger coupling: DC

Trigger voltage: midpoint set

Trigger mode: Auto

POS knob: Trigger offset

十一、 REF

Choose a waveform of channel as sample and with the other one. When user press REF, the appear . Figure 2-30

Signal source: CH1 or CH2

Save: Saving the waveform chosen

Invert: Refer to the waveform invert

十二、 MENU/CH OFF OR ON

Press MENU/CH button to be on or off menu

To observe the waveform clearly, please press close menu and waveforms you don’t want.

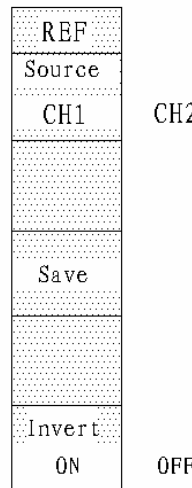

CH2 save it which compare following menu will

OFF

or waveform.

OFF button twice to

Figure2-30

Chapter 3: Application & Examples

Example 1: Taking Simple Measurements

To see a signal in a circuit, but the amplitude and frequency are unknown. You want to quickly display the waveform, please use automatic setup (AUTO).

1. Press the CH1 menu, set the probe menu attenuations to $10\times$, and set the switch to $10\times$ on the probe
2. Connect signal to the probe
3. Press the AUTO button

The oscilloscope sets the vertical, horizontal, and trigger controls automatically. To optimize the display of the waveform, you could adjust these controls manually.

Example 2: Selecting Automatic Measurements

The oscilloscope could take automatic measurements on most signals. To measure the amplitude and frequency, do these steps as follow:

1. Measure amplitude

Press MEASURE → Select CH1 to set measurement source.

Press Voltage → Voltage 2/3 to set measurement page.

Press Vpp to select peak-to-peak amplitude and the result will be displayed on the left bottom of the screen.

2. Measure frequency

Press MEASURE → Select CH1 to set measurement source.

Press Time → Time1/3 to select measurement page.

Press Freq to select frequency measurements and the value will be displayed on the left bottom of the screen.

Example 3: Measuring a signal delay and gain of the circuit

If you want to measure the gain and signal delay of an amplifier, do the test as shown in Figure 3-1:

1. Connect signal to the probe.

2. Press the AUTO button.
3. Press the CH1 button to select CH1, adjust the VOLTS/DIV and POSITION to adjust the position of CH's waveform.
4. Measure the amplitude of the signal CH1 and CH2 according to the above example, Amplification Factor $K = V2/V1$.
5. Press MEASURE.

Press **Time** to select measurement Type.

Press **Time3/3** to select measurement page to select Delay1 $\rightarrow 2$.

The value will be displayed on the left bottom corner of screen.

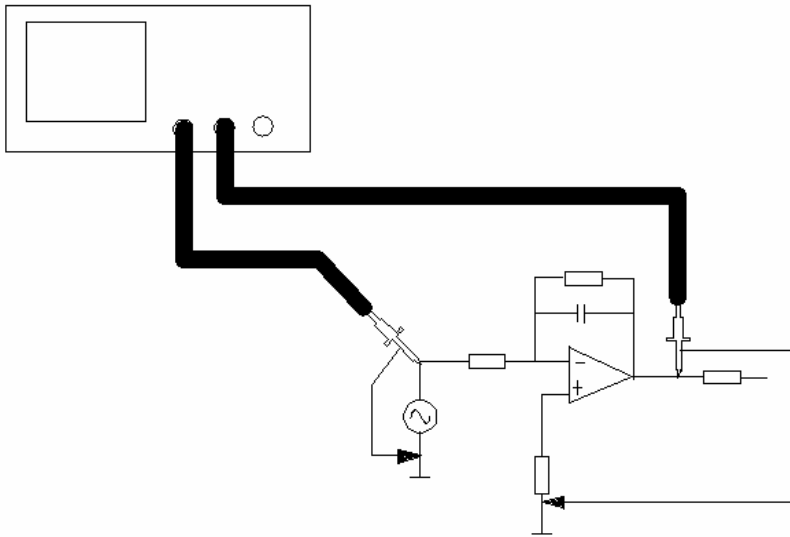

Figure 3-1

Example 4: Cursor Measurements

You could use the cursors to quickly make time and voltage measurements on a waveform.

To measure the ring frequency at the rising edge of a signal, do these steps:

1. Press CURSOR key to see the **Cursor menu** → Press **Mode** to set **Manual** mode → Press **Type** to select **Time** measurement → Rotate CH1 POSITION knob to place cursor 1 on the first peak of the ring.

Rotate CH2 POSITION knob to place cursor 2 on the second peak of the ring. You can see the time between cursors (ΔX) and frequency ($1/\Delta X$) in the Cursor menu. Figure 3-2 shows the measured ring frequency is 100MHz.

Measuring Ring Amplitude

2. Press CURSOR key to see the **Cursor menu** → Press **Mode** to set **Manual** mode → Press **Type** to select **Voltage** → Rotate CH1 POSITION knob to place cursor 1 on the top of the first positive peak of the ring. Rotate CH2 POSITION knob to place cursor 2 on the bottom of the first negative peak of the ring.

You can see the voltage between cursors (ΔV) in the Cursor menu.

Figure 3-3 shows that the measured ring amplitude is 380mV.

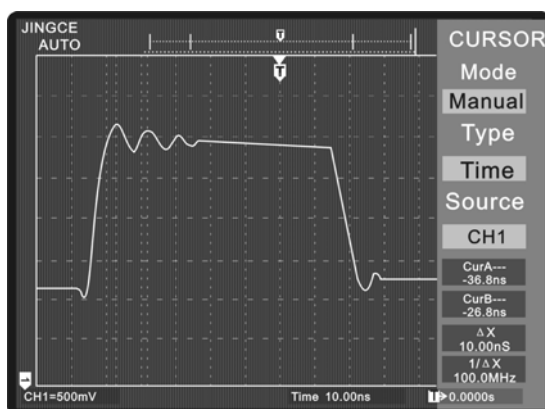

Figure 3-2

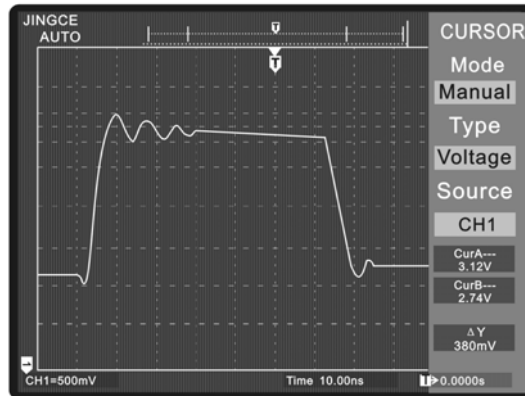

Figure 3-3

Example 5: Analyzing Signal Detail

When included peaks and noise in signal, Peak Detect in Menu ACQUIRE can separate the signal from the random noise.

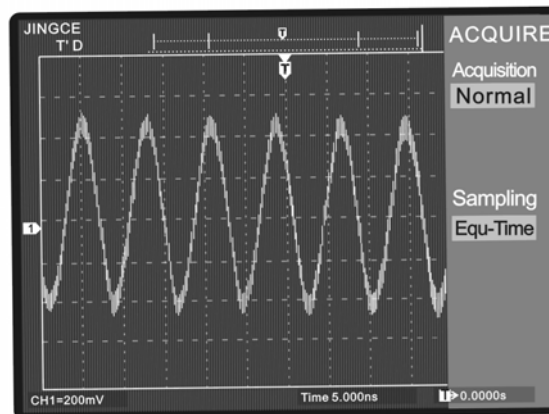

Figure 3-4

If the signal contains more random noise, observing and analyzing the waveform is difficult, you can use Average in Menu ACQUIRE. The average function could reduce the random noise to check the signal detail easily.

Figure 3-5 shows the averaged waveform is a running average over the specified number of 64.

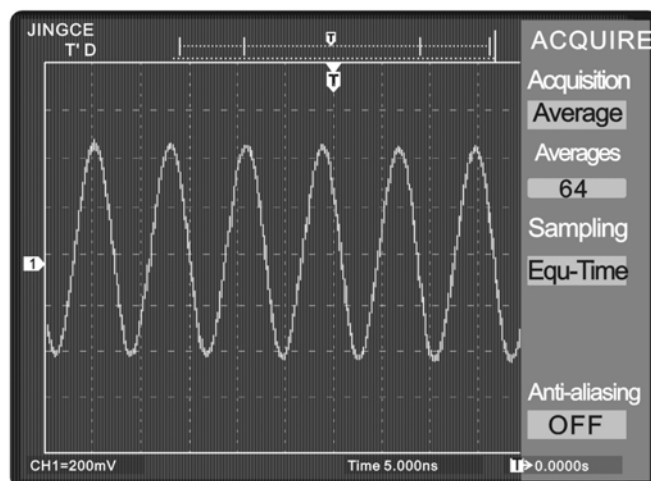

Figure 3-5

Example 6: Displaying a Single-Shot Signal

Capturing a Single-Shot Signal is an advantage of the digital oscilloscope.

It can display clearly and stability after capture. To capture a single event, you need to gather some pre-test knowledge in order to correctly set up the vertical and horizontal mode、VOLTS/DIV and trigger mode.

The following steps show you how to use the oscilloscope to capture a single event.

1. Press the CH1 menu. Set the probe 、 the channel attenuation and VOLTS/DIV、 SEC/DIV.
2. Press TRIGGER button in the Trigger control area to display the menu.

Press **Edge** to select trigger mode.

Press **Slope** to select **Rising**.

Press **Source** to select **CH1**.

Press **Mode** to select **Single**.

Press **Coupling** to select **DC**.

3. Turn the LEVEL knob to adjust trigger level.
4. Press RUN/STOP button. When the trigger conditions are met, data appears on the display representing the data points that the oscilloscope obtained with one acquisition.

Single-Shot function could capture an emergency spike more effective. If the trigger level is out of the range of the normal signal level, you can capture the spike and the signal waveform before and after the spike.

Example 7: Triggering on a Video Signal

The equipment with video trigger on fields or lines for standard video signals could display Sync signals and video signals on odd field or even field. Also you can select an appointed line of the video signal.

To trigger on the video fields, do these steps:

1. Press TRIGGER key, and push **Mode** to select **Video** mode
2. Press **Source** to select **CH1** as trigger source
3. Press **Polarity** to select **Video polarity**
4. Press **Sync** as **Odd Field** 、 **Even Field**, **All Lines** and **Line Num.**
5. Adjust the vertical POSITION、 VOLTS/DIV、 SEC/DIV to see a complete waveform on the screen. See Figure 3-6 and Figure 3-7.

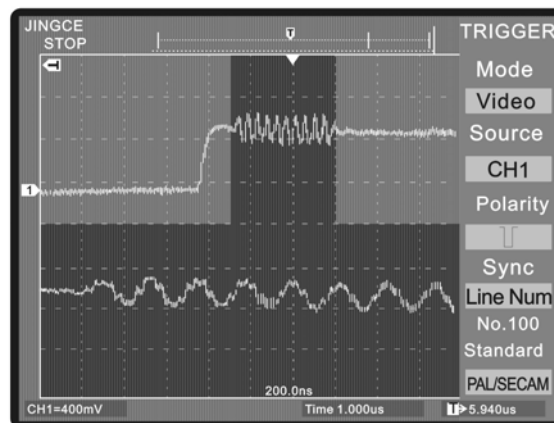

Figure 3-6 Demonstrating line100 color synchronization signal by delaying scan or video trigger mode

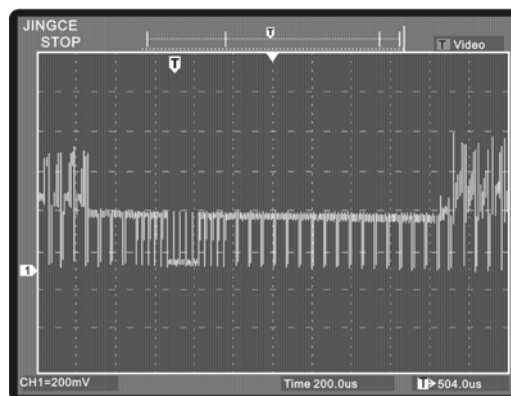

Figure 3-7 field synchronization signal

Example 8: Pass/Fail Test

Press X Mask and Y Mask to adjust the horizontal clearance and the vertical clearance of the signal. Comparing with the pre-defined mask, if the waveform “touches” mask, a “ Fail ” is occur, then

counter once.



It could output fail or pass waveform, and set **Stop on Output** test or not.

Working on the detection of the signal, the oscilloscope displays the data of Fail、 pass and Total on the left upper corner of screen.

Do the steps as following:

1. Press **UTILITY** → **2/2 Menu** → Press **PASS/FALL**.
2. Press **Enable Test** and select **ON** to open the test, select **CH1** as source, and **entry 3/3 menu**.
3. Create mask in the 3/3 menu: Enable the **X Mask**, and turn horizontal **POSITION** to adjust the horizontal clearance. Enable the **Y Mask**, turn vertical **POSITION** to adjust the vertical clearance.

Press **Create Mask** to create a new mask. The mask can be saved and loaded. In Fail/Pass Test, you can create a new test mask, otherwise you can load a pre-defined test mask.

3. In the 2/3 menu: Press **Output** to select the output mode, fail; fail + , Pass; pass . Set **Stop on Output** test or not, and Press **LOAD** to load a pre-defined test mask(the vertical and horizontal clearance).
5. In the 1/3 menu: Select **CH1** as source. the oscilloscope displays the data of Fail、 Pass、 Total、 Wave Forms on the left upper corner of screen, or you can turn off the displayed signal.
6. Press **Operate** to start the test, the displayed information will be changed (See Figure 3-8).

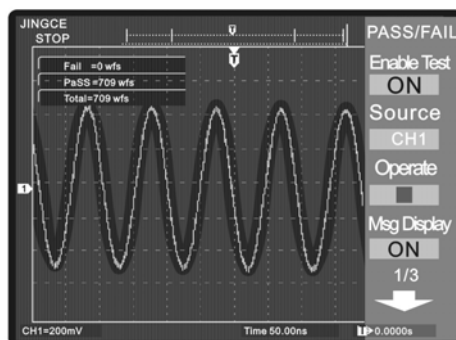

Figure 3-8 waveform failed

Specification

I Vertical system

a、 Input

- 1、 Coupling: DC、 AC、 GND
- 2、 Input impedance: R: $1M\Omega \pm 2\%$; C: $15pF \pm 2\%$
- 3、 Probe attenuation factor: $1\times, 10\times, 100\times, 1000\times$.
- 4、 Maximum input voltage: 400V (DC + ACp-p).
- 5、 Relative delay between two channels: About 150ps.

b、 Characteristic

- 1、 A/D resolution: 8 bit, each channel samples simultaneously.
- 2、 Sensitivity(V/DIV): 2mV/DIV—5V/DIV.
- 3、 Offset range: $\pm 2V$ (2mV/DIV—100mV/DIV), $\pm 40V$ (200mV—5V/DIV).
- 4、 Analog bandwidth: 200MHz (JC2201CA), 150MHz (JC2151), 100MHz (JC2101)
60MHz (JC2061), 40MHz (JC2041), 25MHz (JC2021)
- 6、 One-shot bandwidth: Full bandwidth (1GSa/s sampling rate) or 50MHz (250MSa/s).
- 7、 Bandwidth limitation: 20MHz (Except JC2021)
- 8、 AC coupling: 5Hz— maximum analog bandwidth.
- 9、 Rising time: 1.8ns, 2.3ns, 3.5ns, 5.8ns, 8.7ns, 14ns (Corresponding to the analog bandwidth above)
- 10、 V/DIV error:
 - 2mV/DIV—5mV/DIV: $\pm 4\%$
 - 10mV/DIV or above: $\pm 3\%$

Note: (Normal or average acquisition).

II Time-base system:

1、 Sampling rate:

10Sa/s — 1GSa/s (Real-time); 50GSa/s (Equivalent); (JC2000CA/MA)

10Sa/s — 250MSa/s (Real-time); 50GSa/s (Equivalent); (JC2000C/M)

2、 Waveform interpolation: $\sin(x)/x$

3、 Memory depth: 4K per channel or 1M per channel in **SCAN** mode.

4、 SEC/DIV: 2ns/DIV—50s/DIV in 1—2—5 sequence (For JC2151);

Extend to 20ps/DIV while delayed scan enabled.

5、 Sampling rate and delay accuracy: $\pm 100ppm$ ($\geq 1ms$ timing interval).

6、 Measurement accuracy of time interval (ΔT) (Full bandwidth):

Single: $\pm (1 \text{ sampling interval} + 100ppm \times \text{readouts} + 0.6ns)$;

≥ 16 averaged: $\pm (1 \text{ sampling interval} + 100ppm \times \text{readouts} + 0.4ns)$;

III Trigger system

Sensitivity:

a、 Edge:

DC coupling: 1DIV (DC—full bandwidth); For CH1 or CH2.

EXT: 100mV (DC—10MHz); 200mV (DC—full bandwidth).

EXT/5: 500mV (DC—full bandwidth).

AC coupling: If $\geq 50Hz$, the same as DC coupling.

LF rejection: Component below 8KHz attenuated.

HF rejection: Component above 150KHz attenuated.

b、 Level:

Internal: $\pm 12\text{DIV}$ reference to the center of screen.

EXT: $\pm 1.6\text{V}$

EXT/5: $\pm 8\text{V}$

c、 Video trigger:

Internal: 2DIV.

EXT: 400mV.

EXT/5: 2V.

Note: standard NTSC、 PAL、 SECAM acceptable.

c、 Pulse:

Positive less than, equal to, greater than: width 20ns—10s.

Negative less than, equal to, greater than: width 20ns—10s.

Trigger offset: 1s for pre-trigger; 14DIV for delayed.

Hold-off: 100ns—1.5s

Set level to 50%: effective if input signal is $\geq 50\text{Hz}$.

IV Measurement

Cursor:

Manual mode: Voltage difference ΔV , time difference Δt , $1/\Delta t$ (Frequency) between cursor.

Track mode: Voltage and time difference between two cross cursor.

Auto mode: Cursor displays when auto-measurement enabled.

Auto-measurement:

Following parameter measurable: V_{p-p} , V_{amp} , V_{max} , V_{min} , V_{top} , V_{base} , V_{avg} , V_{rms} ,

V_{ovr} , V_{pre} , Frequency, Period, Rise time, Fall time, +Width, -Width, +Duty, -Duty, Delay 1—2.

V Miscellaneous:

Display: 5.7" STN LCD, 320×240 dot matrix.

Color: Mono or 256 colors.

Contrast: Adjustable.

Brightness (Typical): 350cd/m² (Color LCD).

Backlight: CFL (Color), LED (Mono).

Probe compensation signal: 3V, 1KHz.

Power Supply: AC 100V—400V; 45Hz—65Hz.

Power consumption: $\leq 50\text{W}$.

Fuse: 2A, T class, 250V.

Environment requirements:

Operation temperature: 10°C—40°C.

Storage temperature: -20°C—60°C.

Humidity: $\leq 85\%$

Altitude: $\leq 3000\text{m}$ (Operation) or 15000m (Non-operation)

Dimension: JC1000 series 285 (W) × 155 (H) × 120 (D).

JC2000 series 312 (W) × 145 (H) × 300 (D).