

Proximity Sensor/Switch

E18-D80NK



Description

A very cheap, easy to assemble, easy to use Infrared sensor with a long detection distance and has less interference by visible light. The implementations of modulated IR signal immune the sensor to the interferences caused by the normal light of a light bulb or the sun light. This sensor has a screwdriver adjustment to set the appropriate detected distance to make it useful in many applications, and then gives a digital output when it senses something within that

range. This sensor does not measure a distance value. It can be used for collision avoidance robot and machine automation. The sensor provides a non-contact detection.

Specifications

- Input voltage : +5V DC
- Current consumption : > 25mA (min) ~ 100mA (max)
- Dimension : 1.7cm (diameter) x 4.5cm (length)
- Cable length : 45cm
- Detection of objects : transparent or opaque
- Diffuse reflective type
- Sensing range : 3cm to 80cm (depends on obstacle surface)
- NPN output (normally high)
- Environment temperature : -25 °C ~ 55 °C

Pin Configuration

- Red wire : **+5V**
- Green wire : **GND**
- Yellow wire : **DIGITAL OUTPUT**

Sample Program

```
void setup()
{
  // initialize serial communication at 9600 bits per second:
  Serial.begin(9600);
  // make the pin 2 as an input:
  pinMode(2,INPUT);
}

void loop()
{
  // read the input pin:
  int irread = digitalRead(2);
  // print out the reading of IR:
  Serial.println(irread);
  delay(1); // delay in between reads for stability
}
```

Wiring Diagram

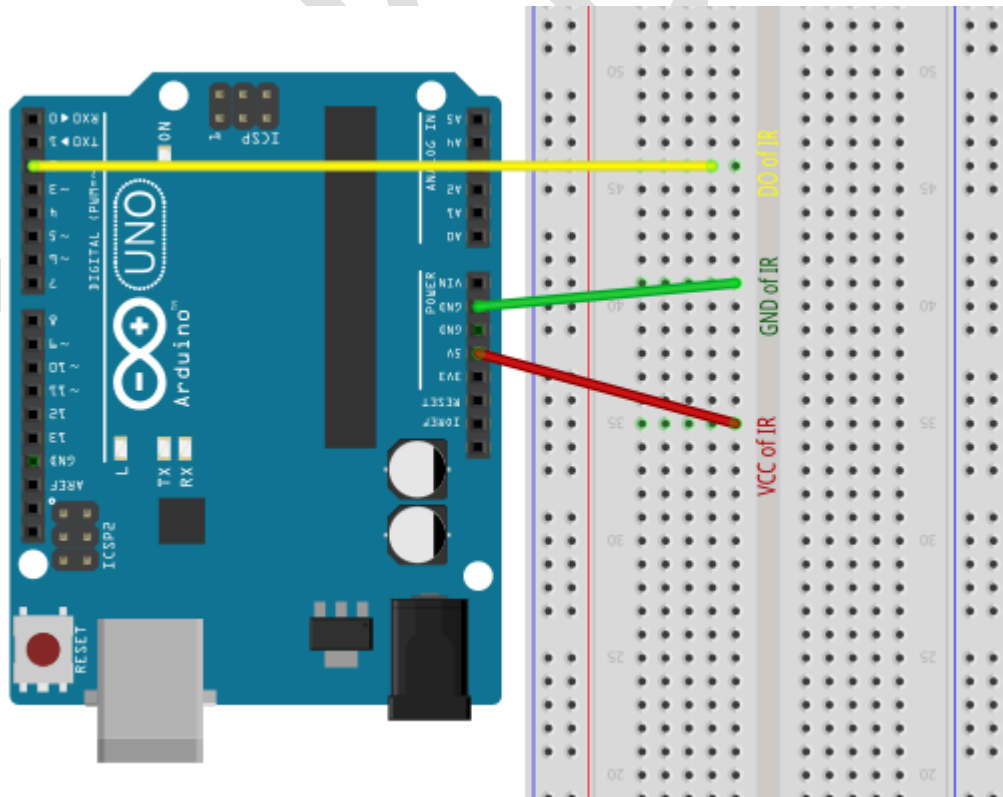

Testing

1. Please check all the connections from the given wiring diagram.
2. Type the sample program in your Arduino sketch then upload.
3. Open the serial monitor in the upper right corner.
4. When there is no object in front of the proximity sensor, the output must be 1.

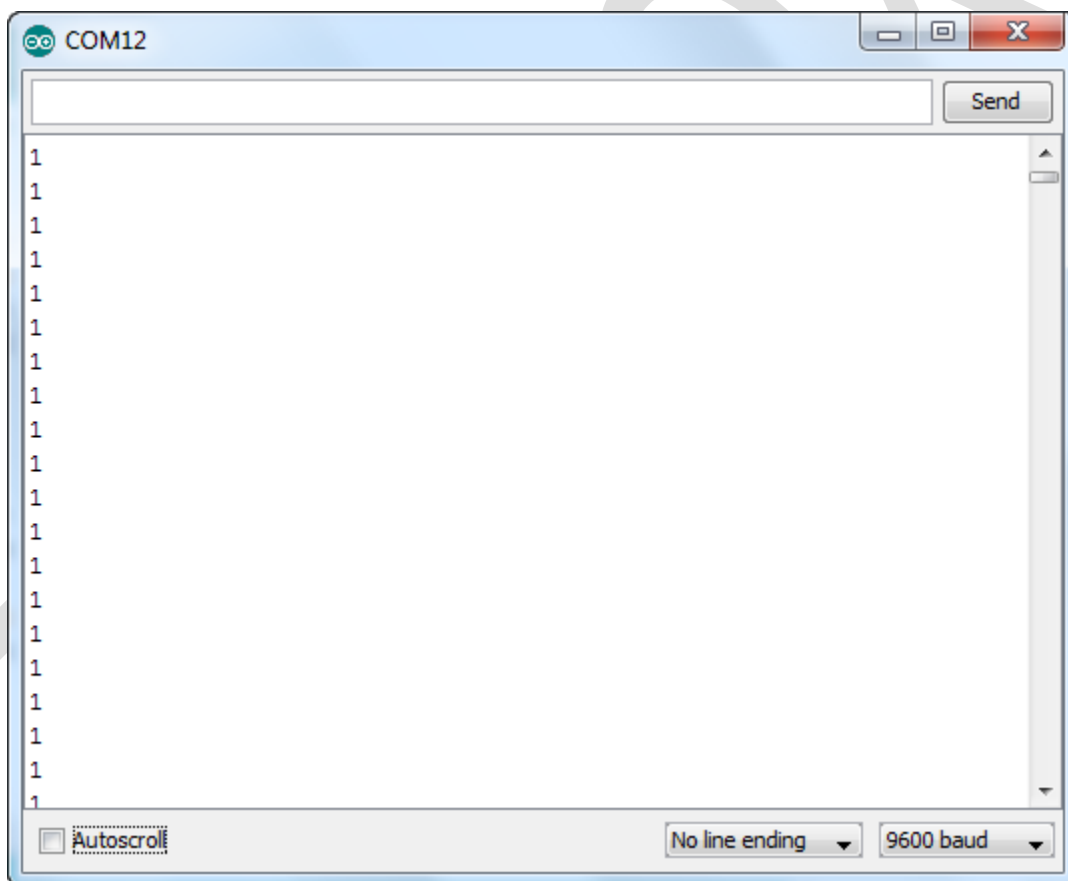

5. Try to put an object in front of the proximity sensor, the proximity sensor will light and the output will become 0.

Note:

* If there is no change in the output of proximity sensor, try to move the object closer.

* Adjust the screw in the proximity sensor to change the range of detection.

